

1500 BTUH | INDOOR/OUTDOOR, UL TYPES 12, 4 & 4X AVAILABLE

Engineered & manufactured to endure the most difficult of environments and applications. Thermal Edge air conditioners will exceed environmental requirements in applications like Steel, Food Processing, Petro-Chemical, Cement, Paper & Pulp and Plastics.



Digital Temperature Controller

- Programmable set point and temperature controls
- Visible Error and/or alarm messaging
- System status indication & keypad lockout function

Active Condensate Evaporation System

- Constant elimination of condensate
- Increases unit efficiency by pre-cooling refrigerant

Key Design Features

- Sloped top to allow for water runoff
- Designed with rigid chassis and seam welded shroud
- Thoughtful interior design for easy maintenance
- Narrow body style fits on 12" enclosure

Unit Efficiency

- Temperature operated condenser fan reduces power inrush and saves energy
- Highly efficient rotary compressor
- Fully insulated & sealed cabinet
- Thermal Expansion Valve to maintain cooling capacity over a broad ambient temperature range

Compressor Protection System

- High & Low refrigerant cutouts with fault indication
- Compressor anti short cycle protection
- Compressor run capacitors reduce power inrush, save energy and increase compressor life

OPTIONS:

- High Ambient
- Remote Controller
- Corrosion Protection
- Controller Programming
- Open Door Kill Switch
- Remote Control/Monitor
- Extended Temp. Probe
- Dry Contact
- Custom Finish
- Diagnostics

Model	UL Type	BTU/Hour	Material	Voltage/Phase/Hz.	Running Amps	Max. Amb. Temp.	H x W x D	Unit Weight (lbs.)
NE01512612	12	1500	Powder coated steel	115/1/60	3.44	125°F	22" x 11.8" x 8.5"	51
NE01512604	4	1500	Powder coated steel	115/1/60	3.44	125°F	22" x 11.8" x 8.5"	51
NE0151264X	4X	1500	Stainless steel	115/1/60	3.44	125°F	22" x 11.8" x 8.5"	51
NE0151264XL4	4X	1500	Mill finish aluminum	115/1/60	3.44	125°F	22" x 11.8" x 8.5"	41
NE01523612	12	1500	Powder coated steel	230/1/60	2.67	125°F	22" x 11.8" x 8.5"	53
NE01523604	4	1500	Powder coated steel	230/1/60	2.67	125°F	22" x 11.8" x 8.5"	53
NE0152364X	4X	1500	Stainless steel	230/1/60	2.67	125°F	22" x 11.8" x 8.5"	53
NE0152364XL4	4X	1500	Mill finish aluminum	230/1/60	2.67	125°F	22" x 11.8" x 8.5"	43

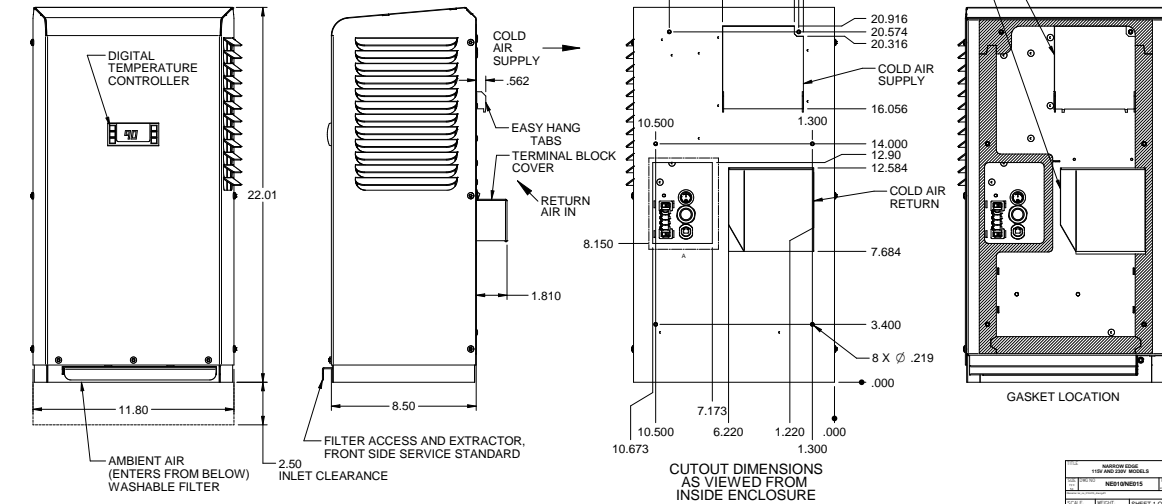
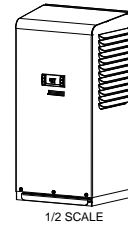
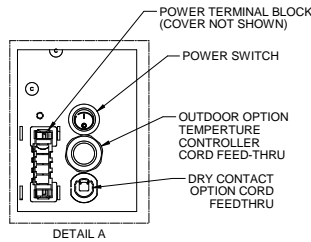
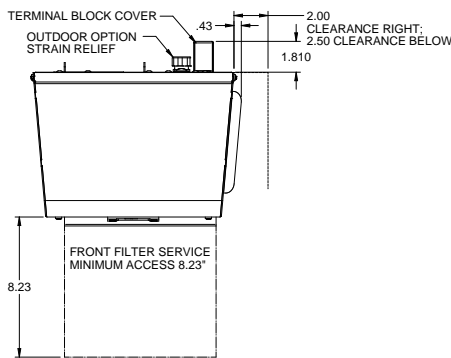
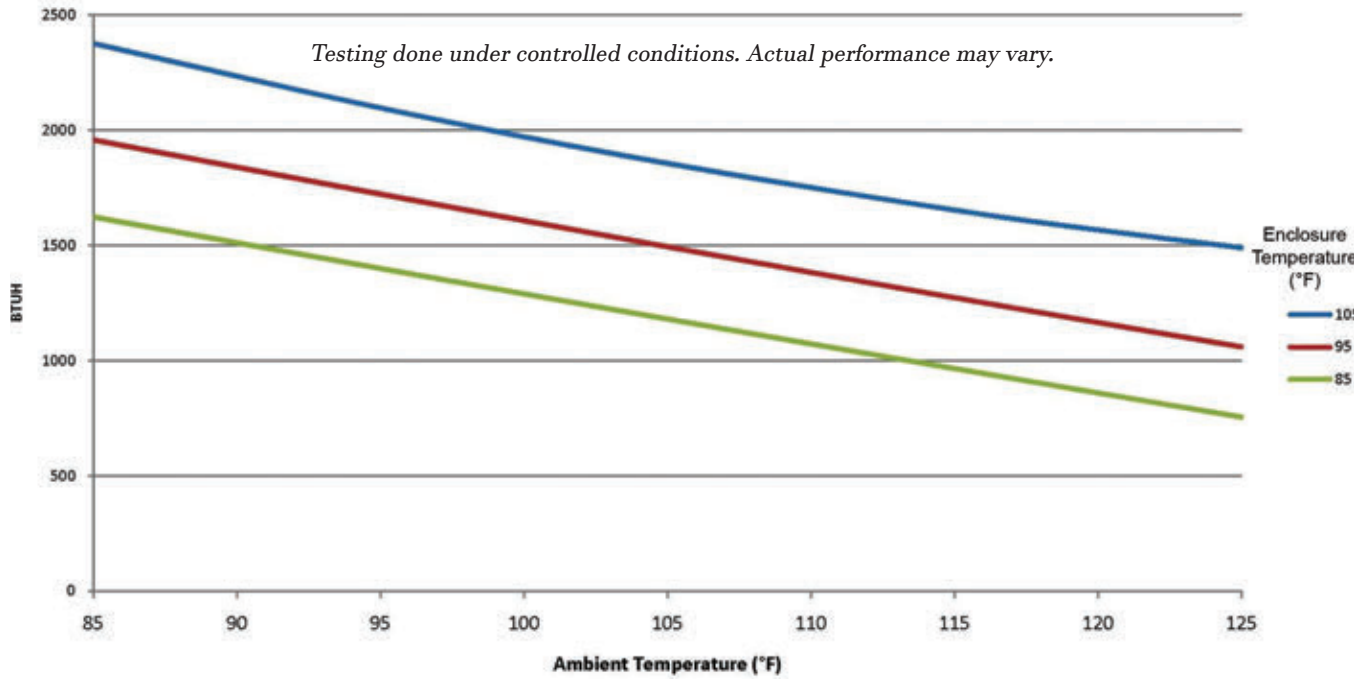

MODEL		PART NUMBER	
110V	220V	110V	220V
110V	220V	110V	220V
110V	220V	110V	220V

ATTENTION: If ordering a replacement for a Thermal Edge air conditioner, please include the part number and serial number of the unit being replaced in your order. This will ensure that we ship a replacement that is compatible with the cutout dimensions and power connection features of the older model. All information subject to change without notice.