

Thermal Edge Inc.TM

TEMPERATURE CONTROL SOLUTIONS FOR ELECTRICAL ENCLOSURES

AIR CONDITIONER OPTIONS

Corrosion Protection
Dry Contact
Open Door Kill Switch
Remote Control & Monitor
Remote Controller
Ambient Packages
Vibration Package
Redundant System
2" Louvered Frame & Filter
Digitally Controlled Integrated Heat Package
Universal Mounting Plate
Hazardous Location Enclosure Air Conditioning Systems



MADE IN AMERICA MATTERS...

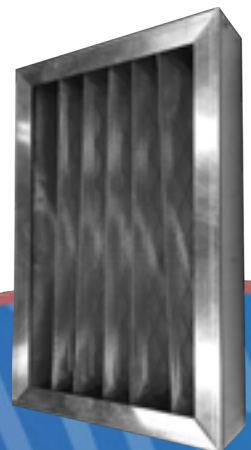
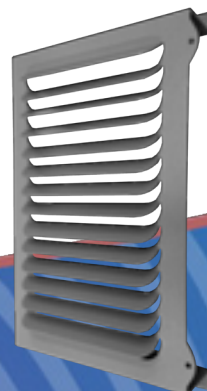

AIR CONDITIONER OPTIONS

RULES & EXCEPTIONS:*

1. Hazardous Location units are only available with the following options:

- Corrosion Protection
- Low Ambient
- Remote Controller
- Dry Contact, Normally Open
- Special Controller Programming
- External heater control (for Haz Loc enclosure heaters)
- All Filter Options
- Extended Temperature Probe
- Vibration Resistant
- Custom Paint

2. All CS011 air conditioners with Heater option may not include:

- Remote Controller option
- Modbus-RTU option

3. C-Level corrosion protection is strongly recommended for:

- 316 Stainless Steel Air Conditioners

**If ordering a replacement for a Thermal Edge air conditioner, please include the part number and serial number of the unit being replaced in your order. This will assure that we ship a replacement that is compatible with the cutout dimensions and power connection features of the older model.*

CORROSION PROTECTION

The thermal edge protective coating options for coils and copper tubing provide the very best protection against corrosion due to acids, solvents, salt, chemicals and more.

A-LEVEL PROTECTION (C1)

Coated condenser coils. Included in NEMA Type 4X units. Available in NEMA Types 12 and 4.

B-LEVEL PROTECTION

Coated condenser and evaporator coils. Available in NEMA Types 12, 4 (C2) and 4X (C5).

C-LEVEL PROTECTION*

Coated condenser coil, evaporator coil and refrigeration tubing. All copper joints are brazed with 45% silver solder, then cleaned and epoxy painted, including the condenser fan guards and electrical components near the condensing section. Available in NEMA Types 12, 4 (C3) and 4X (C6).

EPOXY COIL COATING - ELECTROSTATICALLY APPLIED & BAKED

State of the art corrosion resistance, particularly on thin edges. Lead free formulation with improved corrosion protection. Uniform film build. Excellent thermal transfer properties.

Properties:

- Salt Spray ASTM B117 | D53167 10,000 Hours Minimum
- Humidity ASTM D1735-99 1000 Hours Minimum
- Water Immersion ASTM D870-97 240 Hours Minimum



*C-Level Protection is strongly recommended for 4X applications requiring 316 stainless steel housing.
All information subject to change without notice.

DRY CONTACT

HIGH TEMPERATURE ALARM

This option provides an early warning capability for your enclosure when a high temperature alarm is activated. A 6' cable attached to the dry contact relay can be connected to a light, horn, PLC or other alarm notification equipment allowing the alarm to be seen or heard at a distance for immediate attention.

The Dry Contact is programmed in the air conditioner controller with an individual set point to monitor the enclosure temperature limit that you require. When the enclosure temperature has exceeded the maximum limit, the contact will activate to notify you that there is a problem in achieving your cooling requirement.

DEFAULT SETTINGS

- 105°F Dry Contact High Temperature Alarm Set Point
- 2°F Recovery Differential
- 3 minute Temperature Alarm Delay

At the default settings the Dry Contact initial conditions are normally open and/or normally closed. When the unit is powered on and the temperature exceeds 105°F for a period longer than 3 minutes the Dry Contact will activate. At this time the normally open contact will close and the normally closed contact will open. This state will remain until the temperature has decreased to 103°F.

Options:

- Normally Open (D1)
- Normally Closed (D2)
- Normally Open & Normally Closed (D3)
- Compressor Status & High Temperature Alarm (D4)

This option provides a normally open dry contact that closes when the compressor is operating, plus a normally open & normally closed high temperature alarm. 6' cables attached to the dry contact relays can be connected to a light, horn, PLC or other alarm notification equipment allowing the alarm to be seen or heard at a distance for immediate attention.

- Power On Status & High Temperature Alarm (D5)

This option provides a normally open dry contact that closes when power is being supplied to the air conditioner, plus a normally open & normally closed high temperature alarm. 6' cables attached to the dry contact relays can be connected to a light, horn, PLC or other alarm notification equipment, allowing the alarm to be seen or heard at a distance for immediate attention.

OPEN DOOR KILL SWITCH (K4) & DOOR SWITCH ADD-ON KIT



The Thermal Edge Open Door Kill Switch is designed to automatically shut off the enclosure air conditioner when the door of the enclosure is opened. When the door is closed, the air conditioner will resume normal operation. Each door switch is supplied with a 7-foot low-voltage cable and a mounting bracket.

WIRING DIAGRAM FOR DOOR SWITCH ADD-ON KIT (PART NO. 53058-KIT)

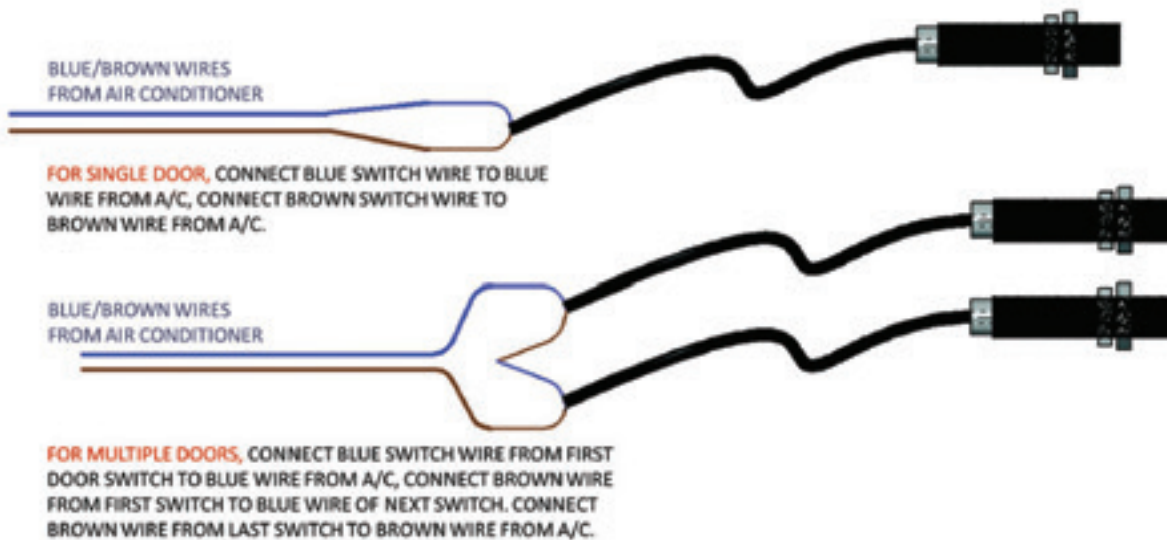

CONFIGURATION	ORDER INFORMATION
1 Air Conditioner : 1 Door	Order Option K4 for 7' cable + Proxy Sensor, K5 for 16' cable + Proxy Sensor
1 Air Conditioner : 1 to 2 doors MAX	Order Option K6 plus one Door Switch Add-on Kit (Part No. 53058-Kit) for the additional door (proxy sensor)
Low voltage Proxy Sensor Wires	Order Option K7 for low voltage wires only (For Proxy and Mechanical Sensor)

OPEN DOOR KILL SWITCH (K0) SP/NO MULTI-VOLTAGE

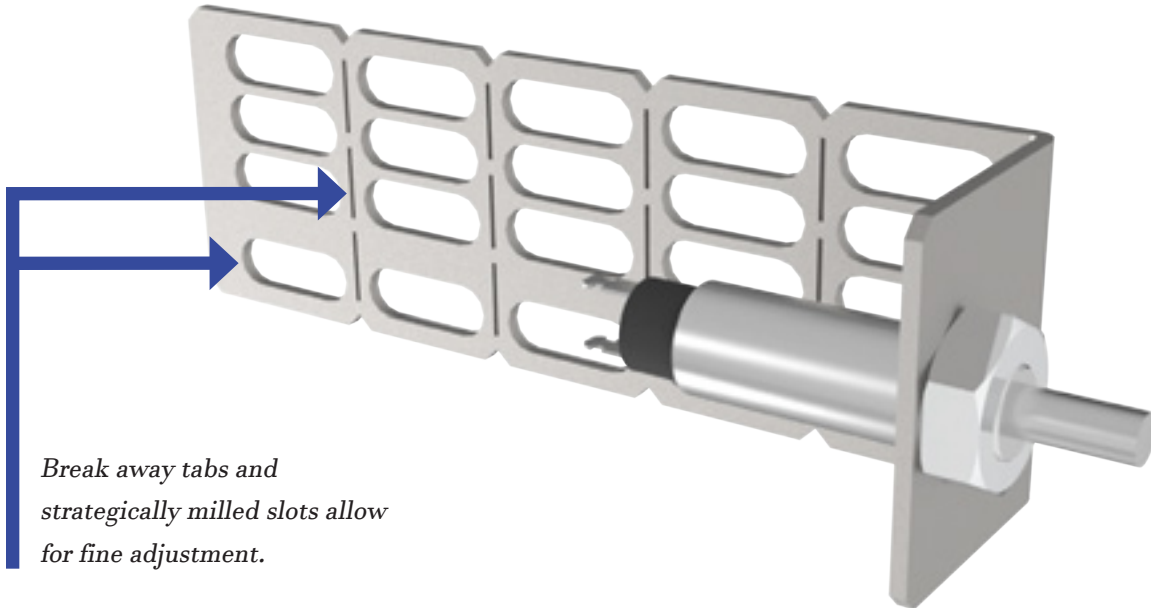

Break away tabs and strategically milled slots allow for fine adjustment.

CHARACTERISTICS & FEATURES:

- 16-Gauge stainless steel construction
- N.O. Plunger style switch
- Part no. 53054-Kit (includes 12" pig tails pre wired to the sensor terminals)
- Slot spacing allows placement on .5 or .625 rack mount holes.

CONFIGURATION	ORDER INFORMATION
1 Air Conditioner: 1 Door	Order Option K0 for Mechanical SP/ST, N.O. multi-voltage door switch
1 Air Conditioner: 2+ Doors	Order K0, + Door Switch Add-on kit (Part No. 53054-KIT) for each additional door

REMOTE CONTROLLER OPTION (BX)

When having our Programmable Digital Controller on the face of our Air Conditioner does not fit your application, Thermal Edge offers the Remote Controller Option.

HOW IT WORKS

This option moves the controller into your enclosure using a 10' cable. A Field installed; universal mounting bracket will also be provided for your location preference. The powder coated universal mounting bracket is constructed of 16-gauge sheet metal and will provide limited access to the controller for secure applications. As shown below*, the air conditioner has no openings on the face of the unit. In addition, the Remote Controller Option and a filter hood or louvered cover option are required for high pressure wash-down applications.



**Unit pictured left is a UL Type 4X Air Conditioner with the remote controller option. Drawing to the right illustrates the application and installation of the remote controller option.*

TAMPER RESISTANT CONTROLLER COVER (B6, B7)



Electrical equipment placed in locations frequented by the public should be securely locked and all controls made inaccessible to reduce the risk of vandalism or unauthorized tampering with the operation of the enclosure air conditioner.

The keypad on the controller can be locked to prevent unauthorized access, but the visibility of the controller display sometimes attracts unwanted attention. For that reason, Thermal Edge offers a **Tamper Resistant Cover option for your Digital Controller**, preventing unauthorized access and keeping your controls secure. Available in stainless steel (B7) or painted (B6).

REMOTE CONTROL & MONITOR

The digital controller used in all Thermal Edge air conditioners features the ability to remotely control, monitor and alarm the cooling and heating functions of the air conditioner. This can be done using a PLC connected to an industrial network or a personal computer (PC) connected to an Ethernet network.

PLC CONTROL, MONITOR & ALARM

ModBUS-RTU, RS485 (R1)

- RS485, 2 wire, network connection
- User Supplied Gateway Connection
- RJ45 Ethernet connection to LAN
- Internet connection with static IP address

ALARM ONLY

Dry Contact

- High temperature alarm input signal to PLC
- Normally Open & Normally Closed (D3)

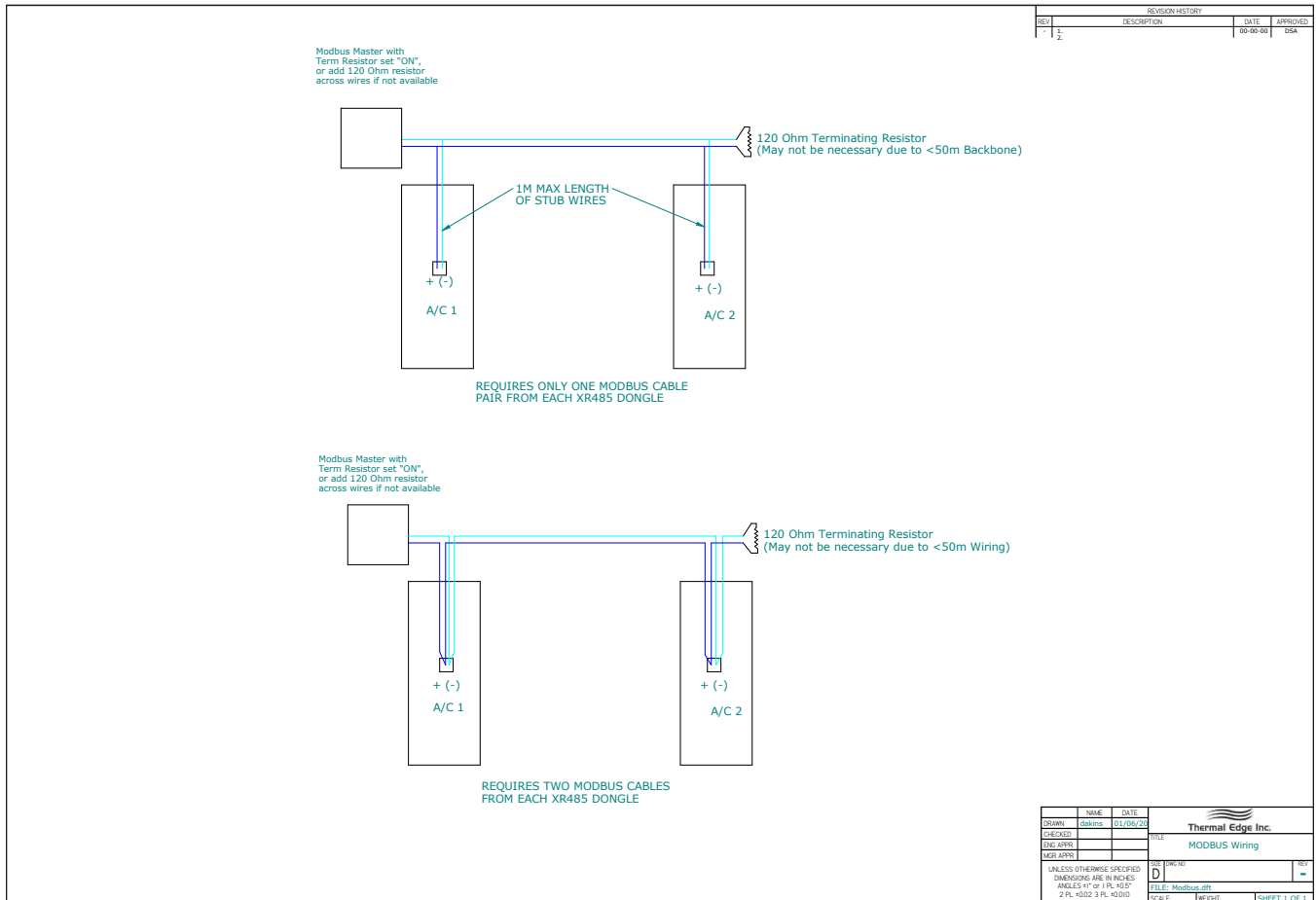

2" SECURITY LOUVERED FRAME AND 2" FILTER

If your application is in a food processing or dirty environment, filter maintenance is crucial. These types of environments can create real problems for an air conditioner that by its very design requires a steady flow of reasonably clean air in order to remove heat from your enclosure. If condenser air flow is reduced by a dirty filter, cooling capacity will be reduced as well.

EXTENDED SURFACE

Thermal Edge offers extended surface, 2" deep filters and filter frame assemblies. These 250 micron stainless steel mesh filters, with 94% efficiency, extend the filter capacity by 400%. The filters are washable and reusable. Life expectancy is determined by the environment and the cleaning procedures. Stainless steel filters are preferred in wash-down applications over aluminum filters.

These deeper filter frames can easily be retrofitted on existing units with standard filters.



LOUVERED FILTER FRAME

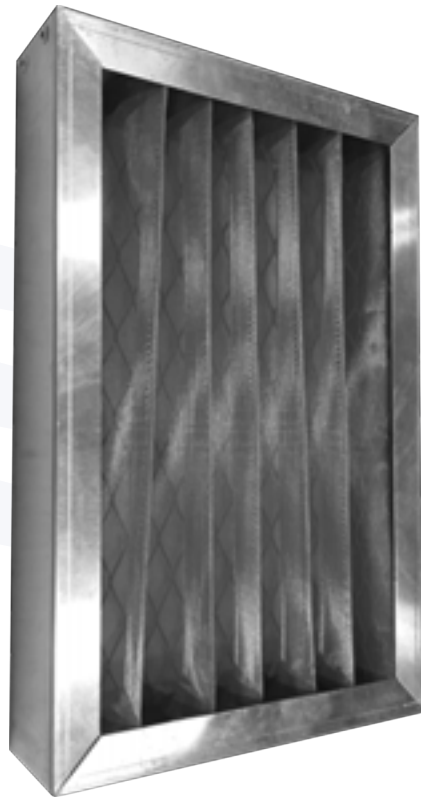

2" PLEATED FILTER



LOUVERED SECURITY FLAT FILTER FRAMES

These filter frames can easily be retrofitted on existing units with standard filters.



Filter media not included, sold separately.



A/C Unit	ANSI Grey Part Number	Aluminum Part Number	304 SS Part Number	316 SS Part Number
CS020	22218-1	22218-3	22218-4304	22218-4316
NE020	22416-1	22416-3	Only avail. in 316 SS	22416-4316
NE030	22416-1	22416-3	Only avail. in 316 SS	22416-4316
NE040	22416-1	22416-3	Only avail. in 316 SS	22416-4316
NE050	22824-1	22824-3	Only avail. in 316 SS	22824-4316
NE060	22824-1	22824-3	Only avail. in 316 SS	22824-4316
NE080	22824-1	22824-3	Only avail. in 316 SS	22824-4316
TM061	22908-1	22908-3	22908-4304	22908-4316
TM081	22908-1	22908-3	22908-4304	22908-4316
HC101	23815-1	23815-3	23815-4304	23815-4316
HC121	23815-1	23815-3	23815-4304	23815-4316
HC151	23815-1	23815-3	23815-4304	23815-4316
HC20C	23815-1	23815-3	23815-4304	23815-4316
HC201	23864-1	23864-3	23864-4304	23864-4316

REPLACEMENT 2" PLEATED FILTER



Thermal Edge offers extended surface, 2" deep replacement filters. These 250 micron stainless steel mesh filters, with 94% efficiency, extend the filter capacity by 400%. The filters are washable and reusable. Life expectancy is determined by the environment and the cleaning procedures. Stainless steel filters are preferred in wash-down applications over aluminum filters.



2" Pleated Filter

A/C Unit	Part Number	Size	Description	Quantity
CS020	44250	9" W x 11" H	304 SS mesh, 250 micron, 94% efficiency	4
NE020	44251	7.3" W x 11.3" H	304 SS mesh, 250 micron, 94% efficiency	4
NE030	44251	7.3" W x 11.3" H	304 SS mesh, 250 micron, 94% efficiency	4
NE040	44251	7.3" W x 11.3" H	304 SS mesh, 250 micron, 94% efficiency	4
NE050	44252	10.3" W x 16.3" H	304 SS mesh, 250 micron, 94% efficiency	4
NE060	44252	10.3" W x 16.3" H	304 SS mesh, 250 micron, 94% efficiency	4
NE080	44252	10.3" W x 16.3" H	304 SS mesh, 250 micron, 94% efficiency	4
TM061	44258	19 "W x 13.75"H	304 SS mesh, 250 micron, 94% efficiency	4
TM081	44258	19 "W x 13.75"H	304 SS mesh, 250 micron, 94% efficiency	4
HC101	44254	14" W x 24" H	304 SS mesh, 250 micron, 94% efficiency	4
HC121	44254	14" W x 24" H	304 SS mesh, 250 micron, 94% efficiency	4
HC151	44254	14" W x 24" H	304 SS mesh, 250 micron, 94% efficiency	4
HC201	44261	14" W x 13.33" H	304 SS mesh, 250 micron, 94% efficiency	6

EXPANDED ALUMINUM REPLACEMENT FILTERS



A/C Unit	Part Number	Size	Description	Quantity
NE010	44200	7.5" W x 9" H	Exp. alum, 250 micron, 60% efficiency	12
NE015	44200	7.5" W x 9" H	Exp. alum, 250 micron, 60% efficiency	12
CS020	44201	9" W x 11" H	Exp. alum, 250 micron, 60% efficiency	12
NE020	44202	7.3" W x 11.3" H	Exp. alum, 250 micron, 60% efficiency	12
NE030	44202	7.3" W x 11.3" H	Exp. alum, 250 micron, 60% efficiency	12
NE040	44202	7.3" W x 11.3" H	Exp. alum, 250 micron, 60% efficiency	12
NE050	44203	10.3" W x 16.3" H	Exp. alum, 250 micron, 60% efficiency	12
NE060	44203	10.3" W x 16.3" H	Exp. alum, 250 micron, 60% efficiency	12
NE080	44203	10.3" W x 16.3" H	Exp. alum, 250 micron, 60% efficiency	12
TM061	44218	19 "W x 13.75"H	Exp. alum, 250 micron, 60% efficiency	12
TM081	44218	19 "W x 13.75"H	Exp. alum, 250 micron, 60% efficiency	12
HC101	44204	14" W x 24" H	Exp. alum, 250 micron, 60% efficiency	12
HC121	44204	14" W x 24" H	Exp. alum, 250 micron, 60% efficiency	12
HC151	44204	14" W x 24" H	Exp. alum, 250 micron, 60% efficiency	12
HC201	44260	14" W x 13.33" H	Exp. alum, 250 micron, 60% efficiency	12

DIGITALLY CONTROLLED INTEGRATED HEAT PACKAGE (HX)

The Thermal Edge Enclosure Heat System is incorporated into the evaporator section of the air conditioner, thereby utilizing the evaporator blower for cooling or heating. Electric heating elements with thermal overloads are available in four ranges to suit most applications. The heater is controlled by our programmable digital controller.

The controller has separate programmable upper and lower control limits for cooling and heating, as well as a programmable dead band to prevent simultaneous operation of heating and cooling. The temperature set points for cooling and heating are set at the factory during production and can be field adjusted in one degree increments. The temperature set points can be protected by a keypad lockout function.

SPECIFICATIONS:

Watts:

- 350 (CS011)
- 500, 1000, or 1500 (HC Series)

Default Settings:

- Heat Set Point: 55°F
- Differential: 3°F

HEATER PACKAGE (below)
as it would appear installed (right)

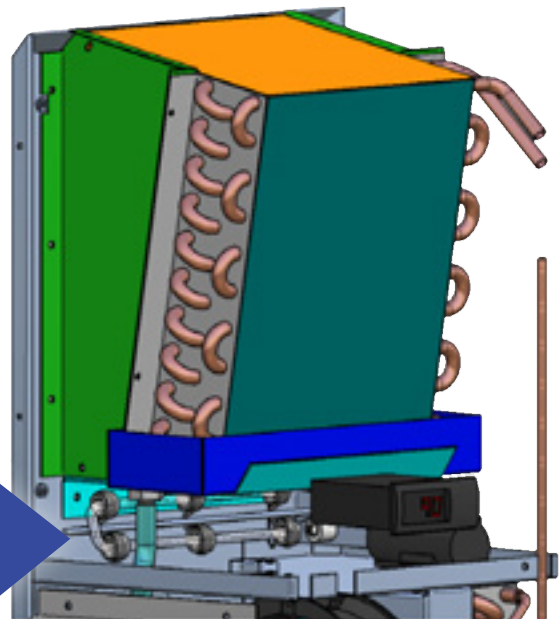
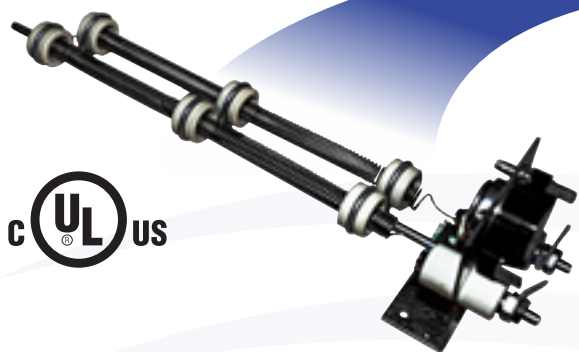

HAZARDOUS LOCATION ENCLOSURE AIR CONDITIONING SYSTEMS (J4)

Thermal Edge Hazardous Location air conditioners are in conformance with all requirements of ANSI/NFPA 70, NEC and CAN/CSA-C22.1, Part I for Class I, Division 2, Groups A, B, C, and D.



SYSTEM FEATURES:

- For purged and non-purged enclosures
- Active, energy efficient, Condensate Evaporation System
- Fully programmable digital controller with built-in alarms and alerts
- Remote controller option places controller inside enclosure
- Thermal Expansion Valve for maximum efficiency when temperature or heat load changes
- Hermetically-sealed compressor, thermal overload protector
- Models range from 2,000 to 20,000 BTUH
- Available in UL types 12, 4 and 4X
- Top Mount and Side Mount*

*Critical components in the NRTL Hazardous Location Listing Report must not be substituted with alternate components. Thermal Edge, Inc. and MET Labs must be notified before changes to any drawings, samples, or required documentation will be approved.

Model	BTU/ Hour	Voltage/ Phase/Hz.	Max. Ambient Temp.	Temp. Code
CS020126	2000	115/1/60	118°F	T6
CS020236	2000	230/1/60	118°F	T6
NE020126	2000	115/1/60	122°F	T4
NE020236	2000	230/1/60	122°F	T4
NE020486	2000	460/1/60	122°F	T4
NE030126	3000	115/1/60	122°F	T4
NE030236	3000	230/1/60	122°F	T4
NE030486	3000	460/1/60	122°F	T4
NE040126	4000	115/1/60	122°F	T4
NE040236	4000	230/1/60	122°F	T4
NE040486	4000	460/1/60	122°F	T4
NE050126	5000	115/1/60	122°F	T4
NE050236	5000	230/1/60	122°F	T4
NE050486	5000	460/1/60	122°F	T4
NE060126	6000	115/1/60	122°F	T4
NE060236	6000	230/1/60	122°F	T4
NE060486	6000	460/1/60	122°F	T4
TM061126	6000	115/1/60	122°F	T4
TM061236	6000	230/1/60	122°F	T4
TM061486	6000	460/1/60	122°F	T4
NE080126	8000	115/1/60	122°F	T4
NE080236	8000	230/1/60	122°F	T4
NE080486	8000	460/1/60	122°F	T4
TM081126	8000	115/1/60	122°F	T4
TM081236	8000	230/1/60	122°F	T4
TM081486	8000	460/1/60	122°F	T4
HC101126	10,000	115/1/60	122°F	T4
HC101236	10,000	230/1/60	122°F	T4
HC101486	10,000	460/1/60	122°F	T4
HC121126	12,000	115/1/60	122°F	T4
HC121236	12,000	230/1/60	122°F	T4
HC121486	12,000	460/1/60	122°F	T4
HC151236	15,000	230/1/60	122°F	T4
HC151486	15,000	460/1/60	122°F	T4
HC201236	20,000	230/1/60	122°F	T4
HC201486	20,000	460/1/60	122°F	T4

VIBRATION PACKAGE (V1)

The Thermal Edge Vibration Package is designed to protect NE model air conditioner components from the effects of moderate vibration. Depending on the model, short rigid refrigerant lines connecting the compressor may be replaced with shock absorbing loops to prevent work hardening and eventual fracture of the copper tubing.

On some models, flexible stainless steel refrigerant lines may be used in place of standard copper tubing to connect the compressor. Fixed insulated clamps are used to restrict vibration at critical points. Electrical wires are over-wrapped where they might rub against hard parts.*

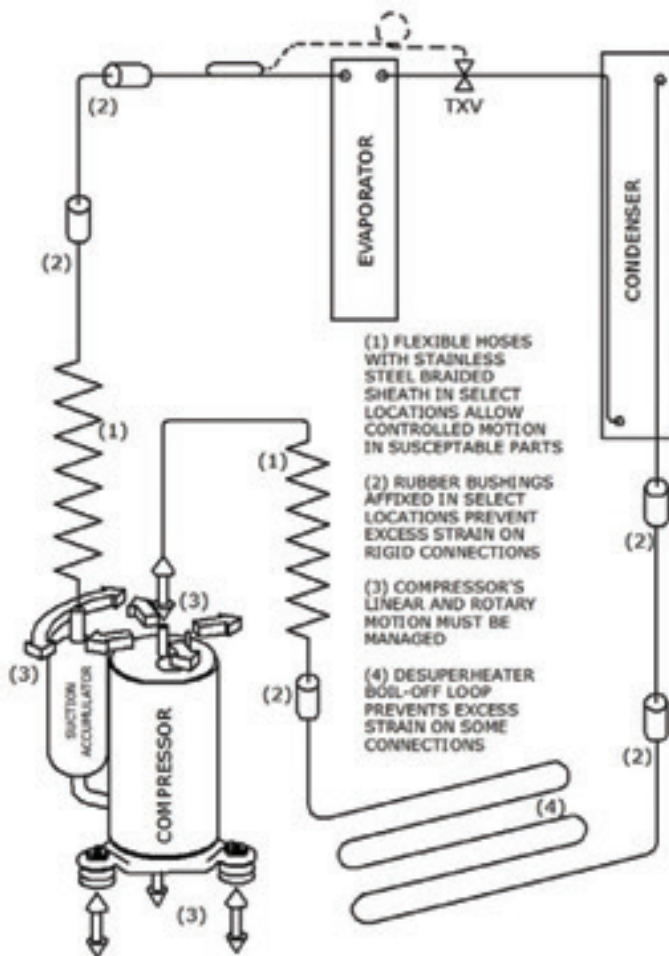

Consists of the Following:

- Fixed rubber bushings limit excess motion
- Stainless steel-sheathed flexible hoses absorb side to side and rotary motion produced by the compressor
- Tubing through the boil off pan absorbs expansion and contraction
- Brazed connections at compressor are high-temp silver solder to avoid hardening
- All wiring is neatly bundled & tied to prevent vibration



**Please consult your Thermal Edge Representative for mounting considerations on severe vibration applications. Varies by Model. All information subject to change without notice.*

DIAGNOSTICS (X1, X2, X3, X4, X5)

Diagnostic Options provide time and money-saving features with web-based system monitoring and remote troubleshooting capabilities.

The screenshot displays a diagnostic interface for two air conditioning units. The top section shows Unit 1 with its evaporator fan (Q2) and compressor (Q1) status, cycle time (60 minutes), and remaining time until switching to Unit 2 (00:20). It also features a panel for Unit 1 alarms, including a controller power status (I5), compressor failure (I7), and evaporator fan failure (I8). The bottom section shows Unit 2 with its evaporator fan (Q4) and compressor (Q3) status, cycle time (60 minutes), and remaining time until switching to Unit 1 (00:00). It includes a panel for Unit 2 alarms (I6) and an optional alarm input (I8). Other features include auxiliary compressor enable controls, PLC status, and door status indicators.

Feature	Redundant Systems			Single Air Conditioner	
	X1	X2	X3	X4	X5
Web-based user interface with configurable settings	HMI Only	Sensors Only	Sensors + HM	Sensors + PLR	Sensors + PLR + HMI
Physical alarm notification in the event of an error	✓	✓	✓	✓	✓
Remote diagnostics and troubleshooting			✓		✓

HMI ONLY: Provides a web-based interface accessible by web browser which displays the status of the programmable logic relay (PLR). End-users may configure five (5) settings through this portal, including the cycle time of both air conditioners, the auxiliary compressor status and enable time, and if installed with the Open Door Kill Switch (K4), the open door delay time prior to system powering off. A hardwired Ethernet connection is required. Compatible with Redundant Systems only (diagnostic options continue on next page).

SENSORS: Allow notification through the Dry Contact Alarm Output in the event a compressor or evaporator becomes disabled. Two (2) sensors are provided (one for the compressor and one for the evaporator fan) for a single air conditioner.

SENSORS + PLR + HMI: Displays the PLR status in PLR equipped air conditioners. Compatible with E5 or E8 redundant systems and any single air conditioner with Option X5.

DIAGNOSTICS (X1)

Compatible with Thermal Edge Redundant Systems (E5, E6, E7, E8)

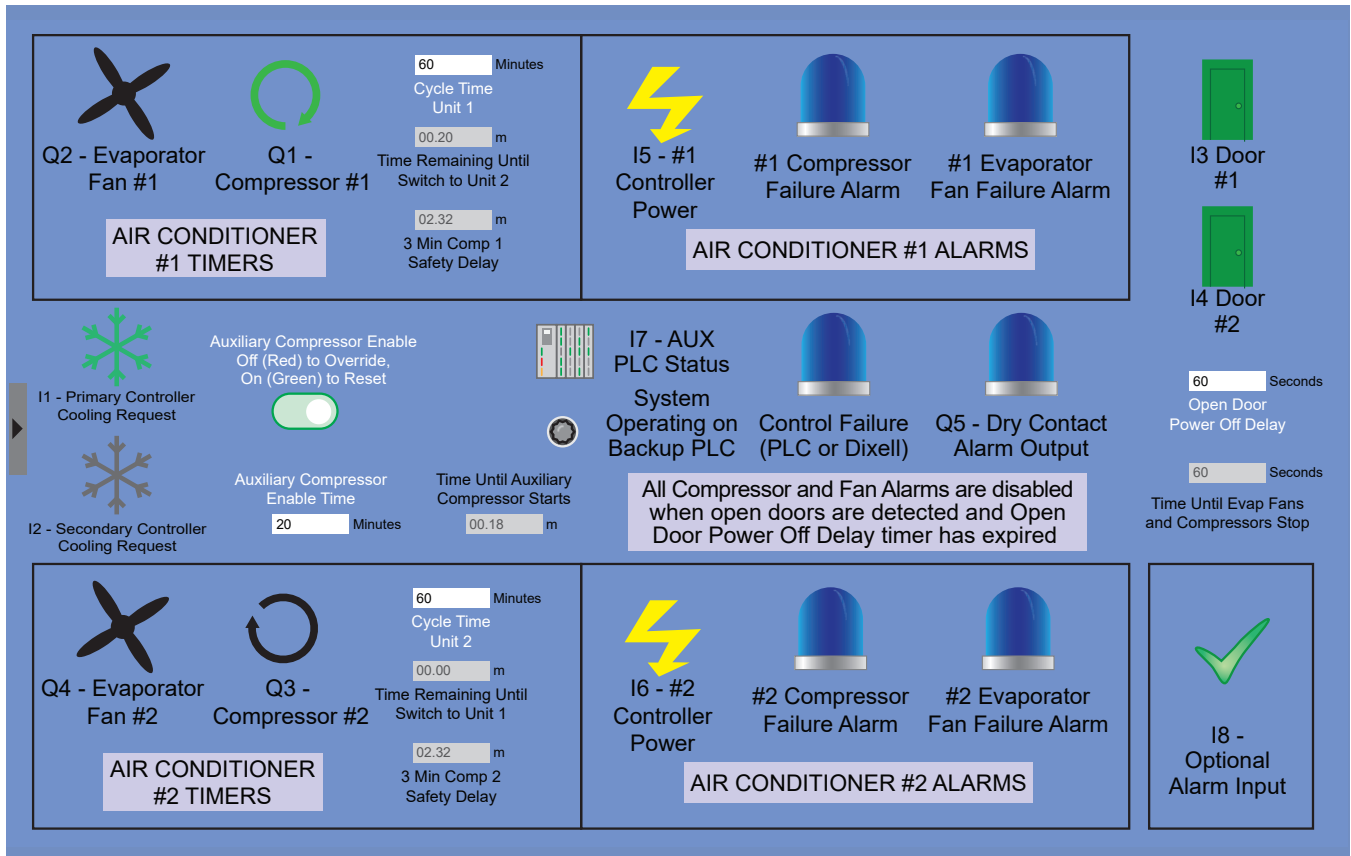

HMI AND REMOTE ACCESS

The HMI provides remote access via a web-based portal which displays how the system should be operating based on what the PLR is calling for. End-users may configure five (5) settings through this portal including the cycle time of both air conditioners, the auxiliary compressor status and enable time, and if installed with the Option K4 – Open Door Kill Switch, the open door delay time prior to the system powering off.

FAILSAFE SYSTEM WITH FULL SYSTEM VISIBILITY

When combined with the E8 Secondary Unit Backup with PLR, end users get a failsafe system with full system visibility for both the primary and secondary system.

PLR* -BASED REDUNDANT SYSTEM (E5, E6, E7, E8)

The PLR-Based Redundant System by Thermal Edge offers:

IMPROVED SERVICE LIFE

Alternating operating run times between two air conditioners, the balanced load sharing reduces wear and tear and improves the service life of the system.

RELIABLE COOLING

In fluctuating or high heat load environments, the system will simultaneously operate both air conditioners until the demand for additional cooling diminishes.

REDUNDANT OR FAILSAFE OPERATION

For reliable cooling without interruption in the event an air conditioner becomes disabled, the Redundant E6 Option automatically calls upon the second air conditioner to deliver the required amount of cooling. For reliable cooling without failure in the event a PLR becomes disabled, the Failsafe E8 Option maintains the critical cabinet temperature by maintaining operation from the backup PLR.

Option Codes:

- **E5** Primary PLR-Based Unit
- **E6** Secondary PLR-Based Unit—provides redundancy should an air conditioner become disabled
- **E7** Replacement Primary PLR-Based Unit
- **E8** Secondary Unit with Backup PLR—provides a failsafe option should the primary PLR become disabled

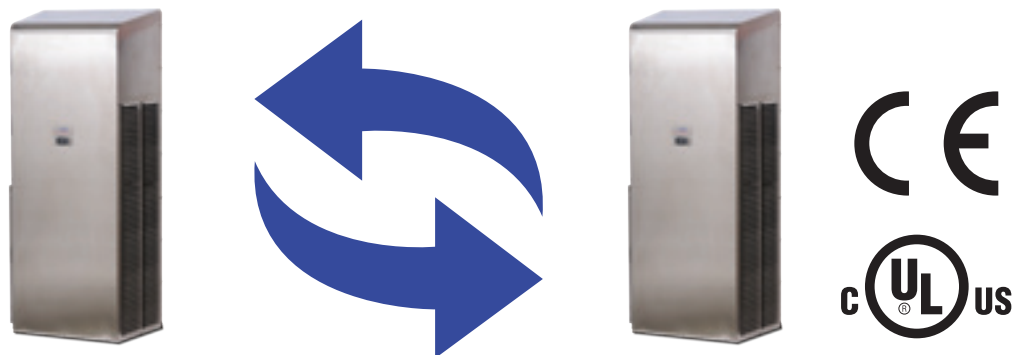

*PLR = Programmable Logic Relay.

All information subject to change without notice.

AMBIENT PACKAGES

LOW AMBIENT* OPTION

The low ambient option consists of circuitry to protect the compressor in a low ambient temperature environment. Heat is applied inside the compressor, where it is needed, to protect it from damage or wear due to stalls and hard starts after long periods in the non-cooling state.

THIS WORKS TOGETHER WITH...

the pressure controlled condenser fan in Thermal Edge air conditioners. The condenser fan cycles off in low ambient temperature conditions, thus allowing rapid warm up. This also reduces the current inrush by not starting the condenser fan when the compressor is turned on.

Low Ambient Package (A1 standard / A2 custom)*

- Special circuit protects compressor from stalls and hard starts at ambient temperatures below 50°F and during long periods of compressor off-state
- Constant low current in compressor motor during the non-cooling state provides internal heat to compressor
- Ambient temperatures as low as 20°F
- Below 20°F requires a special quote

High Ambient Package (A3)

- Optimize Air Conditioner during manufacturing to achieve improved performance at high ambient conditions
- Standard maximum ambient temperature is 125°F or 131°F
- Most models can be optimized to achieve 131°F operation
- Some models can be optimized to achieve 140°F operation

**Low Ambient option MAY NOT be combined with High Ambient option, unless pre-approved by engineering.*

WHAT IS MODBUS RTU?

Serial communications open protocol that can be used by any manufacturer to communicate data across multiple industrial devices

PRIMARY DEVICE

Device that is requesting information. Only device in system that can initiate communication

SECONDARY DEVICE

Device that responds to requests from primary device. Each secondary device is assigned a unique ID.

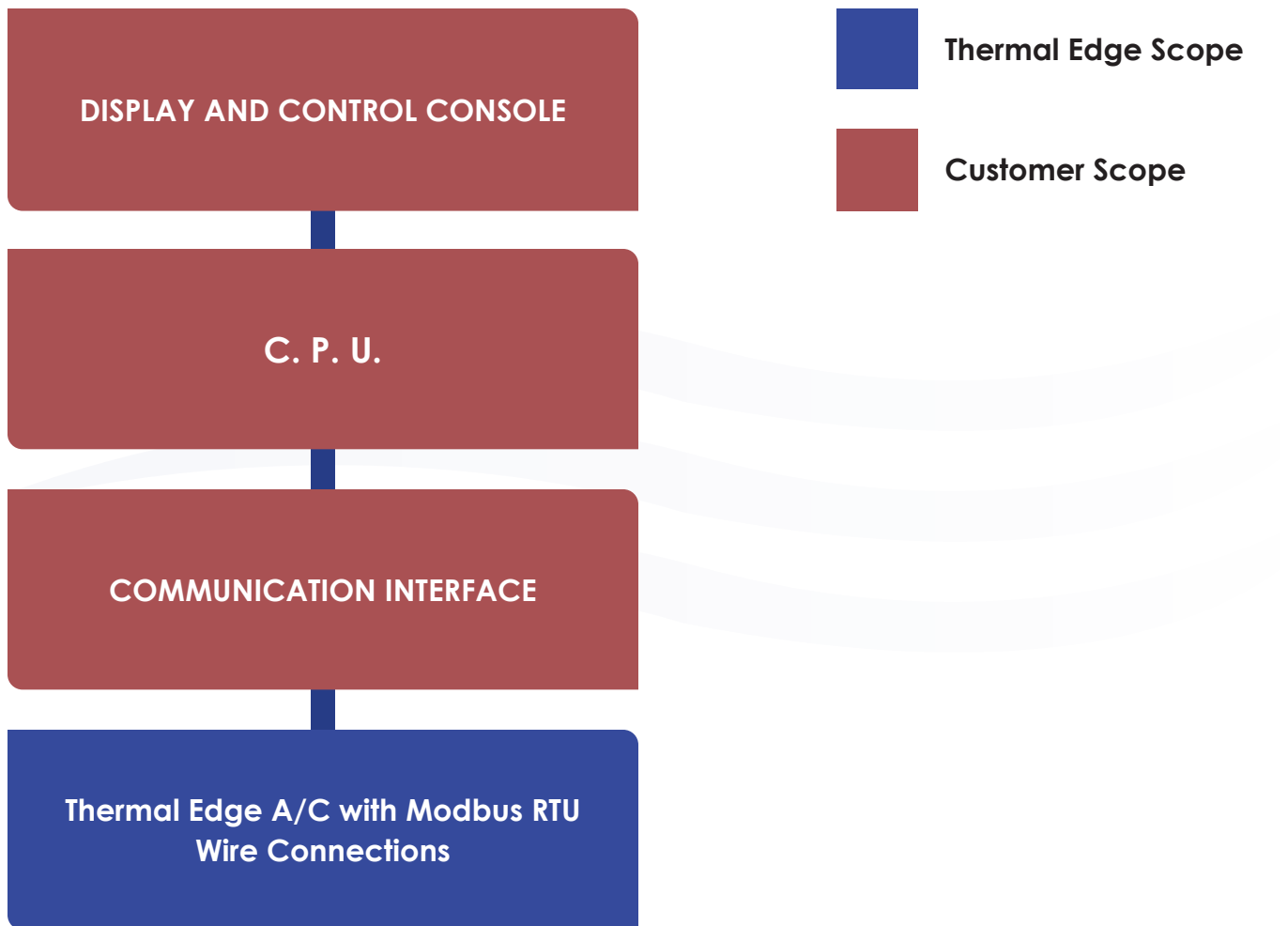

Thermal Edge air conditioners with the Modbus RTU (R1 option) are equipped with two RS485 wire connections to connect to customer supplied interface

ADVANTAGES OF MODBUS RTU

ADVANTAGES:

- Allows customers to monitor and control devices remotely
- Can perform diagnostics remotely to reduce down time and labor costs
- Collecting and monitoring data from Modbus RTU device can allow for proactive maintenance to prevent damage to equipment in your enclosure

SOME TYPES OF DATA IN MODBUS RTU

- Cooling Set Point
- Enclosure Temperature
- Condenser Temperature
- System Pressure

USING DATA FROM MODBUS RTU DEVICE

Modbus RTU provides a method for customers to assess status information, review active alarms, and perform diagnostics on their industrial equipment.

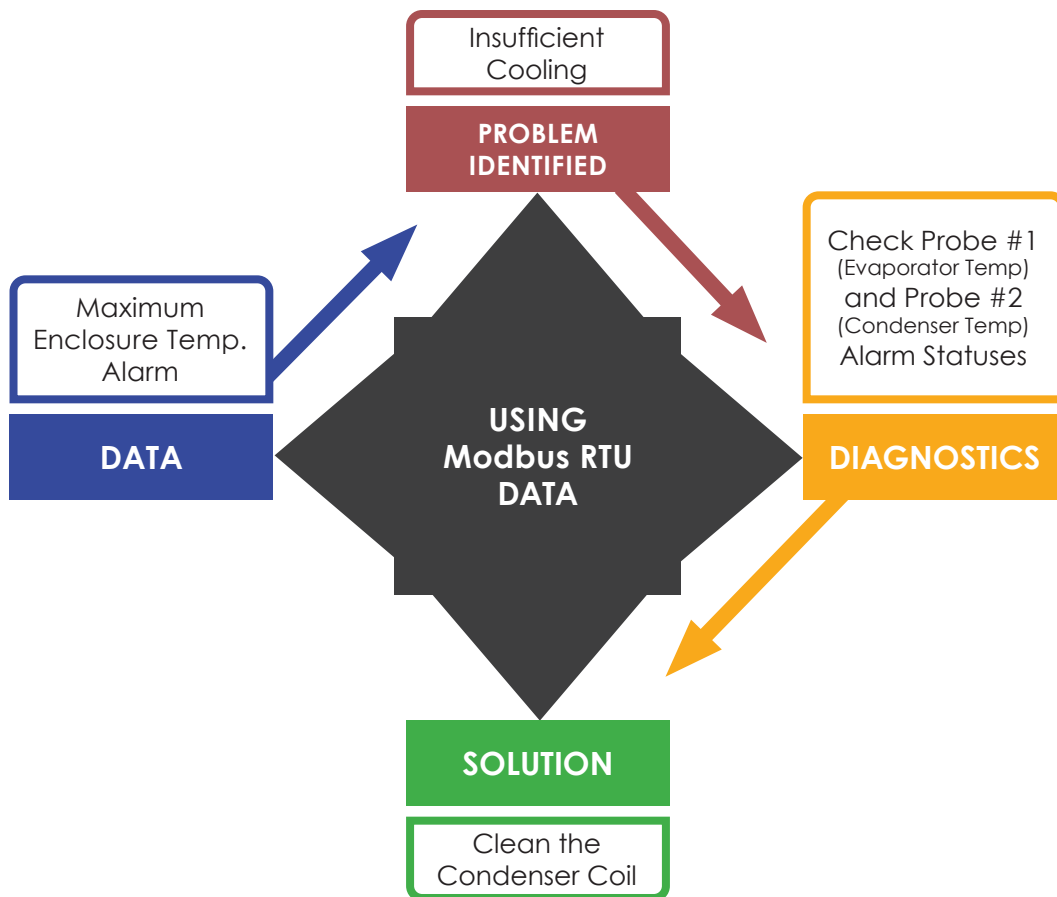

UNIVERSAL MOUNTING PLATE

The universal mounting plate allows you to mount a Thermal Edge Enclosure Air Conditioner to your enclosure when you need to replace another manufacturer's model.

WITH THERMAL EDGE YOU GET:

- Energy-saving condensate evaporation
- Digital programmable controller with protection and alarm circuits
- Thermal Expansion valve for efficient refrigerant control

THERMAL EDGE

UNIVERSAL MOUNTING PLATE:

- Easily replace another company's A/C unit
- Covers the existing cutout and has the cutouts for Thermal Edge unit
- Provide us with the existing model number, and we do the rest.



ALUMINUM HOUSINGS

INDOOR/OUTDOOR, UL TYPE 4X

Engineered & manufactured to endure the most difficult of environments and applications. Thermal Edge mill finish aluminum air conditioner housings will exceed environmental requirements in applications like Traffic Control and Telecom Outside Plant cabinets.

Aluminum Finishings:

- **L4** - Aluminum, Mill Finish (115/230 V)
- **L5** - Aluminum, Mill Finish (460 V)
- **L6** - Aluminum, Mill Finish (48 VDC)

Also Available:

- Aluminum Louvered Covers for Flat Filters
- 2" Louvered Filter Frames for 2" Pleated Filter



**NO WATER DRIPS
FROM THERMAL EDGE
ENCLOSURE AIR
CONDITIONERS**



PASSIVATION OPTION (M2)

When your application requires extra corrosion resistance on your stainless-steel air conditioners, Thermal Edge offers the option to Passivate the 316 stainless steel parts that make up the unit. The Passivation M2 option is a chemical treatment process that is applied to 316 stainless steels, which further enhances the ability of the treated surface, increasing corrosion resistance.

KEY FEATURES INCLUDE:

- Passivated 316 stainless steel – a chemical treatment of all steel components to remove free iron that can lead to corrosion.
- All internal bare parts are built with passivated 316 stainless steel for a fully corrosion-resistant package.

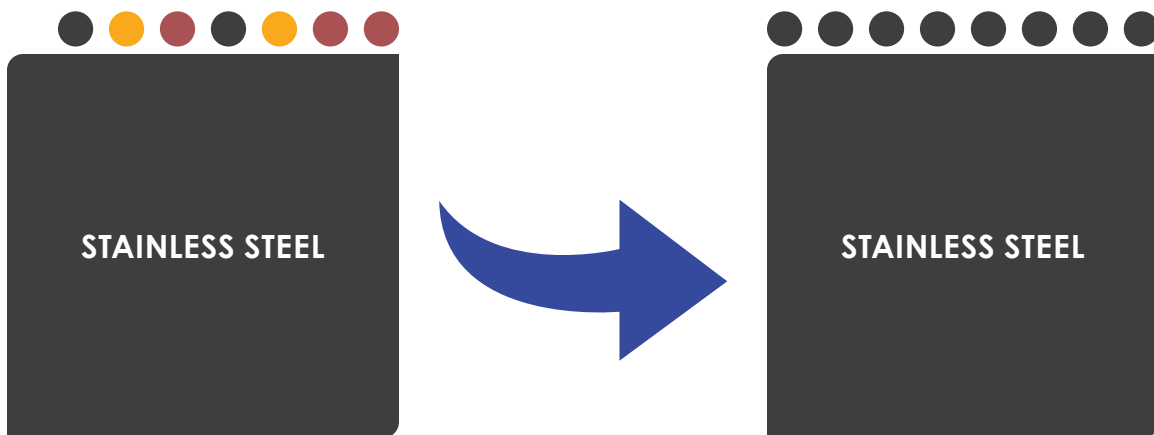

- Iron Oxides
- Dirt
- Chromium Oxide

Result of Passivation

HOODED RAIN AND FILTER COVERS

If your Thermal Edge Air conditioners are exposed to harsh environments, there are some benefits our hooded rain and filter covers can provide. The hooded rain and filter covers can be made in stainless steel, painted steel, and aluminum.

Benefits:

- Coil damage protection from hail.
- Ingress of water from high power pressure washers during wash downs.
- Coil and Louver damage protection from high power pressure washers.
- Filter damage from high power pressure washers.
- Mitigation of falling debris that would normally get pulled into the filter.

NE234 Filter Hood (Standard filter 1")		
Option	Finish	Part No.
F1	ANSI 61 Gray Powder Coat	22419-1
F11	316 Stainless Steel	22419-4316
F12	Aluminum	22419-3

NE234 Condenser Hood (Standard filter 1")		
Option	Finish	Part No.
F6	ANSI 61 Gray Powder Coat	22470-1
F61	316 Stainless Steel	22470-4316
F62	Aluminum	22470-3

NE568 Filter Hood (Standard filter 1")		
Option	Finish	Part No.
F1	ANSI 61 Gray Powder Coat	22819-1
F11	316 Stainless Steel	22819-4316
F12	Aluminum	22819-3

NE568 Condenser Hood (Standard filter 1")		
Option	Finish	Part No.
F6	ANSI 61 Gray Powder Coat	22880-1
F61	316 Stainless Steel	22880-4316
F62	Aluminum	22880-3

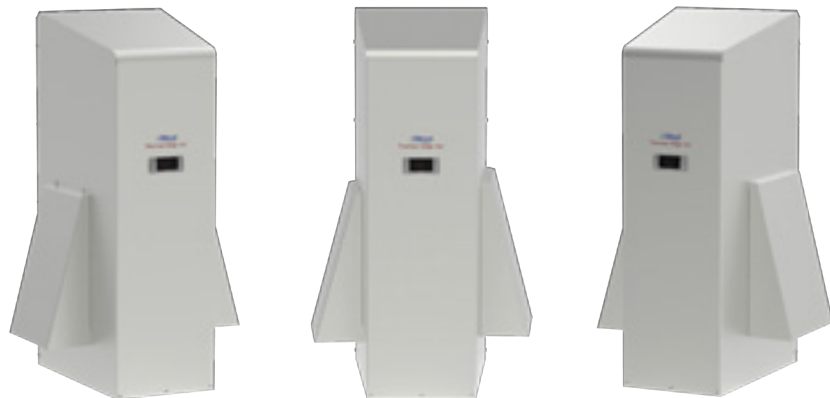

XWEB300D PRO: REMOTE SUPERVISING AND MONITORING

The XWEB300D PRO is an economical, environmentally friendly solution that allows monitoring, analyzing, control, and alarm of your heat sensitive applications from any PC over the Internet to optimize energy, performance and operational savings. The system is easy to install and start up. The XWEB will provide HACCP documentation, energy savings and improved performance in all types of environments.

Extremely well suited for up to 6 or 18 enclosure air conditioner installations. A simple DIN Rail mounting (4 DIN) and the absence of local user interface make the XWEB300D Pro the ideal solution for the remote connection / assistance (via modem) to the plant. Local or remote connection from a PC is made without the need for special software. Standard web browser (Google Chrome, Mozilla Firefox, Microsoft Edge, Apple Safari, Opera) software is required; the information is displayed as Web pages.

XWEB300D Pro supervises the air conditioner(s), and, in case of malfunction alarm, it notifies the assistance center through FAX, SMS or E-mail. The XWEB300D Pro Remote supervisor can also record data relevant to the function of the air conditioner and populate it onto a table.

KEY FEATURES INCLUDE*:

- Data capture and alarm monitoring web server connectable to Thermal Edge Air Conditioners with the-ModBUS-RTU option (R1)
- Structure is based on Linux operating system with WEB pages
- Data shown for all controller values, parameters programming management and alarms
- Powerful graphs showing and exporting functions in Excel® format
- Calendar function to filter alarm transmissions to a particular service
- Alarm sending via FAX, SMS or e-mail
- Possibility to have a connection with a PDA or Smartphone
- Local or remote connection to a PC with a standard browser (Google Chrome, Mozilla Firefox, Microsoft Edge, Apple Safari, Opera) for the data display and monitoring

**Key features and system diagram continue on next page.*

XWEB300D PRO: REMOTE SUPERVISING AND MONITORING

(CONTINUED)

KEY FEATURES INCLUDE:

- 8MB or 24MB internal memory to store up to 1 year data recorded with 15 min sampling time and 6 or 18 controllers
- 15VA max power absorption
- XWEB Pro available for 120V or 230V UL Listed applications
- Software is compliant with advanced safety systems and avoid unauthorized accesses, attacks or other threats thanks to dedicated algorithms for protection and control.

Thermal Edge enclosure air conditioners are listed under UL File #SA32252

Part Number	Description
XWEB3D8C000P	(XWEB) XWEB300D-8C000P PRO 6 Address 110/230V
XWEB3D8D000P	(XWEB) XWEB300D-8C000P PRO 18 Address 110/230V

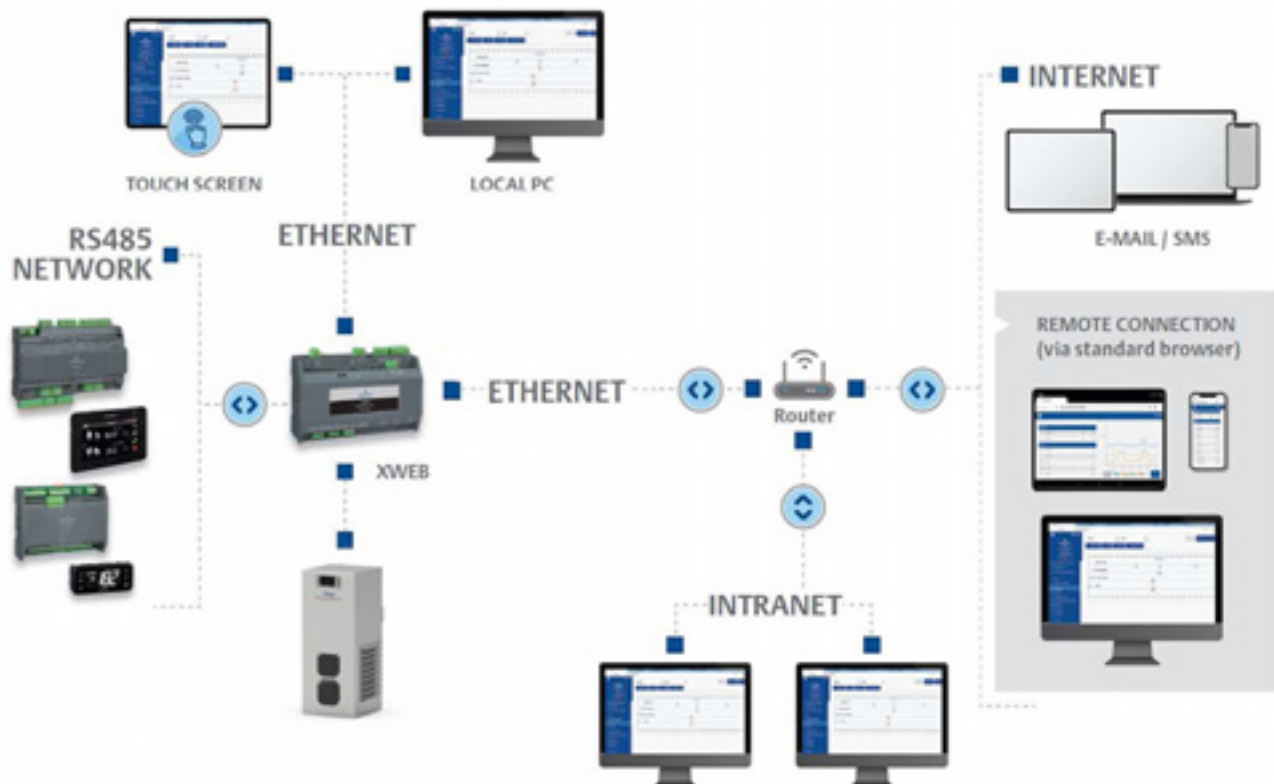

AIR CONDITIONER OPTIONS

	Option Code	Description	CS011	CS011D48	CS020	NE010 NE015	NE020 NE030 NE040	NE020D48 NE030D48 NE040D48	NE050 NE060 NE080	TM061 TM081	HC081	HC101 HC121 HC151	HC20C
Voltage / Frequency	D48	48VDC		X				X					
	105	100V / 50Hz	X			X	X (NE020, NE030)						
	125	115V / 50Hz							X (NE050, NE060)				
	126	115V / 60Hz	X		X	X	X		X	X		X (HC101, HC121)	
	205	200V / 50Hz				X	X (NE030)						
	235	230V / 50Hz			X		X (NE020)		X (NE050, NE060)		X	X (HC101, HC121)	X
	236	230V / 60Hz			X	X	X		X	X		X	X
	237	230V / 50-60Hz							X (NE050, NE060)				
	385	380V / 50Hz					X (NE020, NE030)		X (NE050, NE060)		X	X (HC101, HC121)	X
	405	400V / 50Hz					X (NE020, NE030)		X (NE050, NE060)		X	X (HC101, HC121)	X
	406	400V / 60Hz					X		X	X		X	X
	415	415V / 50Hz					X (NE020, NE030)		X (NE050, NE060)		X	X (HC101, HC121)	X
	485	460V / 50Hz					X (NE020, NE030)		X (NE050, NE060)		X	X (HC101, HC121)	X
	486	460V / 60Hz					X		X	X		X	X
	576	575V / 60Hz					X		X	X		X	X
	605	600V / 50Hz					X (NE020, NE030)		X (NE050, NE060)		X	X (HC101, HC121)	X
	606	600V / 60Hz					X		X	X		X	X
NEMA	12	Type 12	X	X	X	X	X	X	X	X	X	X	X
	4	Type 4	X	X	X	X	X	X	X	X	X	X	X
	4X	Type 4X	X	X	X	X	X	X	X	X	X	X	X
Ambient	A1	Low Ambient, Std.	X		X		X		X	X	X	X	X
	A2	Low Ambient, Custom	X		X		X		X	X	X	X	X
	A3	High Ambient	X	X	X	X	X	X	X	X	X	X	X
	A4	Low Ambient, Std. & High Ambient	X		X		X		X	X	X	X	X
	A5	Low Ambient, Custom & High Ambient	X		X		X		X	X	X	X	X

	Option Code	Description	CS011	CS011D48	CS020	NE010 NE015	NE020 NE030 NE040	NE020D48 NE030D48 NE040D48	NE050 NE060 NE080	TM061 TM081	HC081	HC101 HC121 HC151	HC20C
Remote Controller	B1	Mount Controller inside enclosure (10 ft. Cable)	X	X	X	X	X	X	X	X	X	X	X
	B2	Custom, Parent (5 ft. Cable)	X	X	X	X	X	X	X	X	X	X	X
	B21	Mount Controller inside enclosure (21 ft. Cable)	X	X	X	X	X	X	X	X	X	X	X
	B3	Custom, Child (7 ft. Cable)	X	X					X			X	
	B4	Mount Low Voltage Controller inside enclosure, with Bracket (10 ft. Cable)	X	X	X	X	X	X	X	X	X	X	X
	B5	Low Voltage Controller, No Bracket (Std. 10 ft. Cable)	X	X	X	X	X	X	X	X	X	X	X
	B6	Locking Controller Cover, ANSI 61 Grey	X	X	X	X	X	X	X	X	X	X	X
	B7	Locking Controller Cover, 316 SST	X	X	X	X	X	X	X	X	X	X	X
Corrosion Protection	C1	A-Level Protection Coated Condenser Coil (NEMA 12/4)	X	X	X	X	X	X	X	X	X	X	X
	C2	B-Level Protection Coated Condenser & Evaporator Coils (NEMA 12/4)	X	X	X	X	X	X	X	X	X	X	X
	C3	C-Level Protection Coated Condenser & Evaporator Coils + Coated Tubing (NEMA 12/4)	X	X	X	X	X	X	X	X	X	X	X
	C5	B-Level Protection Coated Condenser & Evaporator Coils (NEMA 4X)	X	X	X	X	X	X	X	X	X	X	X
	C6	C-Level Protection Coated Condenser & Evaporator Coils + Coated Tubing (NEMA 4X)	X	X	X	X	X	X	X	X	X	X	X
Dry Contact	D1	Normally Open	X	X	X	X	X	X	X	X	X	X	X
	D2	Normally Closed	X	X	X	X	X	X	X	X	X	X	X
	D3	Normally Open & Normally Closed	X	X	X	X	X	X	X	X	X	X	X
	D4	Compressor Status N.O. and N.C.			X	X	X	X	X	X	X	X	X
	D5	Power Status N.O. (closed when On) & Hi-Temp Warning N.O and N.C.			X	X	X	X	X	X	X	X	X

	Option Code	Description	CS011	CS011D48	CS020	NE010 NE015	NE020 NE030 NE040	NE020D48 NE030D48 NE040D48	NE050 NE060 NE080	TM061 TM081	HC081	HC101 HC121 HC151	HC20C
Redundant System	E1	Primary*	X	X	X	X	X	X	X	X	X	X	X
	E2	Secondary*	X	X	X	X	X	X	X	X	X	X	X
	E3	Primary, Side by Side Mounting*	X	X	X	X	X	X	X	X	X	X	X
	E4	Secondary, Side by Side Mounting*	X	X	X	X	X	X	X	X	X	X	X
	E5	Primary PLR Based Redundant Unit	X	X	X	X	X	X	X	X	X	X	X
	E6	Secondary PLR Based Redundant Unit	X	X	X	X	X	X	X	X	X	X	X
	E7	Replacement Primary PLR Based Redundant Unit	X	X	X	X	X	X	X	X	X	X	X
	E8	Secondary Redundant Unit with Backup PLR	X	X		X	X	X	X	X	X	X	X
Filter	F1	Painted Filter Hood for Thin Filter			X		X	X	X		X	X	X
	F11	SS Filter Hood for Thin Filter			X		X	X	X		X	X	X
	F12	Aluminum Filter Hood for Thin Filter			X		X	X	X		X	X	X
	F3	Painted Louvered Cover for Thin Filter			X		X	X	X	Std.	X	X	X
	F31	SS Louvered Cover for Thin Filter			X		X	X	X		X	X	X
	F32	Aluminum Louvered Cover for Thin Filter			X		X	X	X		X	X	X
	F4	Painted Louvered Cover + 2" Filter			X		X	X	X	X	X	X	X
	F41	SS Louvered Cover + 2" Filter			X		X	X	X	X	X	X	X
	F42	Aluminum Louvered Cover + 2" Filter			X		X	X	X	X	X	X	X
	F5	Flat Filter for TM								X			
	F6	Std. Painted Filter Hood for Thin Filter & Condenser Hood					X						
	F61	SS Filter Hood for Thin Filter & Condenser Hood					X						
	F62	Aluminum Filter Hood for Thin Filter & Condenser Hood					X						
	Controller Programming	G1	Celsius	X	X	X	X	X	X	X	X	X	X
G2		Special	X	X	X	X	X	X	X	X	X	X	X

	Option Code	Description	CS011	CS011D48	CS020	NE010 NE015	NE020 NE030 NE040	NE020D48 NE030D48 NE040D48	NE050 NE060 NE080	TM061 TM081	HC081	HC101 HC121 HC151	HC20C
Heater	H1	350 W	X										
	H2	500 W			X		X		X	X	X	X	X
	H3	1000 W					X		X	X	X	X	X
	H4	1500 W									X	X	X
	H5	External Heater Control	X		X	X	X		X	X	X	X	X
	H6	350 W with Hygrostat Connection	X										
	H7	500 W with Hygrostat Connection			X		X		X	X	X	X	X
	H8	1000 W with Hygrostat Connection					X		X	X	X	X	X
	H9	1500 W with Hygrostat Connection								X	X	X	X
Hazardous Location	J4	NEC: Class I, Div 2, Groups A, B, C, D			X		X		X	X	X	X	X
Open Door Kill Switch	K0	Mechanical SP/ST N.O. Multi-voltage Door Switch											
	K1	1 = Standard 7 ft. Cable Length	X										
	K15	15 ft. Cable Length							X	X		X	
	K2	7 ft. Cable & Chatsworth brackets, Secondary Redundant Unit							X			X	
	K3	7 ft. Cable & Chatsworth brackets, Primary Redundant Unit							X			X	
	K4	1 Door, 1 AC, 7 ft. Cable	X	X	X	X	X	X	X	X	X	X	X
	K5	1 Open Door Prox Sens, Dtch Cbl.							X			X	
	K6	2 Open Door Prox Sens, Dtch Cbl.							X			X	
K7	Low Voltage Switch Wires Only		X	X	X	X	X	X	X	X	X	X	
Housing Material	L1	316 SS (115/230 V)	X		X	X	X		X	X	X	X	X
	L2	316 SS (460 V)					X		X	X	X	X	X
	L3	316 SS (48 VDC)		X				X					
	L4	Aluminum, Mill Finish (115/230 V)	X	X	X	X	X		X	X	X	X	X
	L5	Aluminum, Mill Finish (460 V)					X		X	X	X	X	X
	L6	Aluminum, Mill Finish (460 V)						X					

	Option Code	Description	CS011	CS011D48	CS020	NE010 NE015	NE020 NE030 NE040	NE020D48 NE030D48 NE040D48	NE050 NE060 NE080	TM061 TM081	HC081	HC101 HC121 HC151	HC20C
Finish	M1	Custom Paint	X	X	X	X	X	X	X	X	X	X	X
	M2	Passivated	X	X	X	X	X	X	X	X	X	X	X
	M3	Anodized	X	X	X	X	X	X	X	X	X	X	X
	M13	RAL 7035 115/230 V	X	X	X	X	X	X	X	X	X	X	X
	M14	RAL 7035 460 V	X	X	X	X	X	X	X	X	X	X	X
Extended Temp. Probe	P1	With 12 ft. Cable	X	X	X	X	X	X	X	X	X	X	X
Remote Control / Monitor	R1	Modbus-RTU (Enclosure mounted controller required for CS2)	X	X	X	X	X	X	X	X	X	X	X
	R2	Ethernet/IP	X		X	X	X		X	X	X	X	X
	R3	Ethernet/IP without 24 VDC Power Supply	X		X	X	X		X	X	X	X	X
	R4	Modbus RTU for Redundant Option with Enclosure Controller, Primary			X	X	X		X	X	X	X	X
	R5	Modbus RTU for Redundant Option with Enclosure Controller, Secondary			X	X	X		X	X	X	X	X
	R6	Modbus with Cat 5 Cable							X				
Hard Start Kit	S1	1 = Hard Start Relay									X	X	
Replacement AC w/ Power Cord	T1	1 = Power Cord Equipped	X			X	X		X		X	X	X
Imperfect	U1	Scratch & Dent	X	X	X	X	X	X	X	X	X	X	X
	U2	Refurbished	X	X	X	X	X	X	X	X	X	X	X
Vibration Resistant	V1						X	X	X	X	X	X	X

	Option Code	Description	CS011	CS011D48	CS020	NE010 NE015	NE020 NE030 NE040	NE020D48 NE030D48 NE040D48	NE050 NE060 NE080	TM061 TM081	HC081	HC101 HC121 HC151	HC20C
Custom Build	WZZ	Other	X	X	X	X	X	X	X	X	X	X	X
Diagnostics	X1	1 = HMI Only, Redundant Systems			X	X		X	X	X	X	X	X
	X2	2 = Diagnostic Sensors, Redundant Systems			X	X		X	X	X	X	X	X
	X3	3 = Sensors with HMI, Redundant Systems			X	X		X	X	X	X	X	X
	X4	4 = Diagnostic Sensors (Incl. PLR), Single Systems			X	X		X	X	X	X	X	X
	X5	5 = Sensors with HMI (Incl. PLR), Single Systems			X	X		X	X	X	X	X	X