



Thermal Edge Inc.TM

TEMPERATURE CONTROL SOLUTIONS FOR ELECTRICAL ENCLOSURES

FILTERED FANS PACKAGES

PLASTIC:

Injection Molded Plastic UL Types 12 & 3R

UL Types 12 & 3R

UL Types 12 & 3R | Accessories

Injection Molded Plastic UL Type 1

METAL:

Powder Coated and Stainless Steel

Accessories | 3R Rain Shrouds

BOTH:

Accessories | Filter Media

Accessories | Thermostats



MADE IN AMERICA MATTERS...



INJECTION MOLDED PLASTIC UL TYPES 12 & 3R

PACKAGE INCLUDES FILTERED FAN & FILTERED EXHAUST VENT

Features:

- Hood-free Type 3R rating
- Storage temperature: -40 to 158 °F
- Operating temperature: 14 to 131 °F
- Noise Level: < 60 dBA
- Secure snap-in installation on 18 to 11 gauge panels
- Integrated perimeter seal
- Sliding grille for easy filter maintenance

Injection Molded UV resistant plastic:

- UL Type 12 color: RAL 7035 light grey
- UL Type 3R color: RAL 9005 jet black

Quiet, efficient ball bearing fans:

- 100,000 hour L10 lifetime @25°C
- Thermal motor protection
- Screwless terminal block electrical connection (28-14 AWG)

Progressive structure synthetic fiber filter medium:

- Washable
- Class G3 per EN 779



Model	Height	Width	Depth
PFFP085	5.91"	5.91"	2.915"
PFFP150	8.03"	8.03"	3.755"
PFFP250	9.84"	9.84"	4.924"
PFFP450	12.8"	12.8"	6.314"

Part Number UL Type 12 (Color: RAL 7035 gray)	Filtered Fan CFM	CFM With Exhaust Filter	Voltage/ Frequency	Rated Current (Amps)	Weight (lbs.)
PFFP085-120-12-XXX	39/46	26/31	115 VAC 50/60	0.26/0.22	1.9
PFFP085-230-12-XXX	39/46	26/31	230 VAC 50/60	0.13/0.10	1.9
PFFP085-D24-12-XXX	28	21	24 VDC	22/71	1.2
PFFP150-120-12-XXX	65/76	50/60	115 VAC 50/60	0.20/0.18	2.5
PFFP150-230-12-XXX	65/76	50/60	230 VAC 50/60	0.126/0.11	2.5
PFFP150-D24-12-XXX	59	44	24 VDC	0.342	1.8
PFFP250-120-12-XXX	135/159	95/112	115 VAC 50/60	0.28/0.27	3.9
PFFP250-230-12-XXX	135/159	95/112	230 VAC 50/60	0.14/0.16	3.9
PFFP250-D24-12-XXX	162	118	24 VDC	1.3	3.8
PFFP450-120-12-XXX	262/285	186/206	115 VAC 50/60	0.68/0.73	8
PFFP450-230-12-XXX	268/296	189/210	230 VAC 50/60	0.31/0.35	8

Part Number UL Type 3R (Color: RAL 9005 black)	Filtered Fan CFM	CFM With Exhaust Filter	Voltage/ Frequency	Rated Current (Amps)	Weight (lbs.)
PFFP085-120-3R-XXB	29/35	18.5/22	115 VAC 50/60	0.26/0.22	2.1
PFFP085-230-3R-XXB	29/35	18.5/22	230 VAC 50/60	0.13/0.10	2.1
PFFP085-D24-3R-XXB	21	14.5	24 VDC	22/71	1.2
PFFP150-120-3R-XXB	53/65	37/45	115 VAC 50/60	0.20/0.18	2.5
PFFP150-230-3R-XXB	53/65	37/45	230 VAC 50/60	0.126/0.11	2.5
PFFP150-D24-3R-XXB	50	31	24 VDC	0.342	1.8
PFFP250-120-3R-XXB	94/115	68/82	115 VAC 50/60	0.28/0.26	3.9
PFFP250-230-3R-XXB	94/115	68/82	230 VAC 50/60	0.14/0.16	3.9
PFFP250-D24-3R-XXB	135	93	24 VDC	1.3	3.8
PFFP450-120-3R-XXB	199/222	141/182	115 VAC 50/60	0.68/0.73	7.9
PFFP450-230-3R-XXB	212/235	150/168	230 VAC 50/60	0.31/0.35	7.9

PFFP085

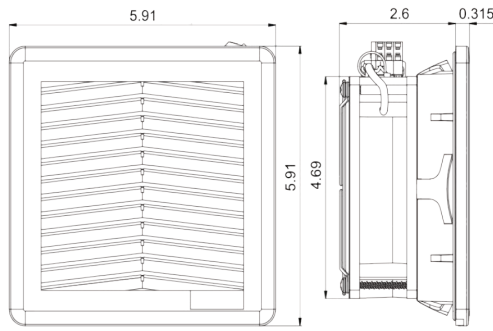

NOTE:
Type 3R cutout
dimensions:
4.921 + .059 - 0

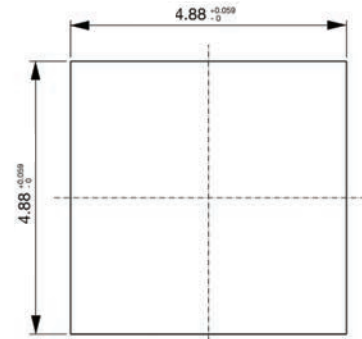

CUTOUT DIMENSIONS (IN)

PFFP150

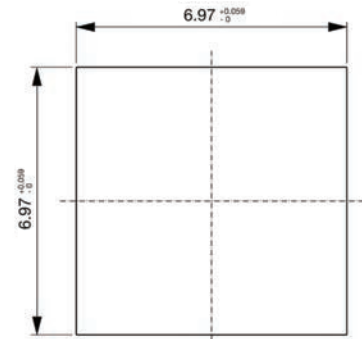
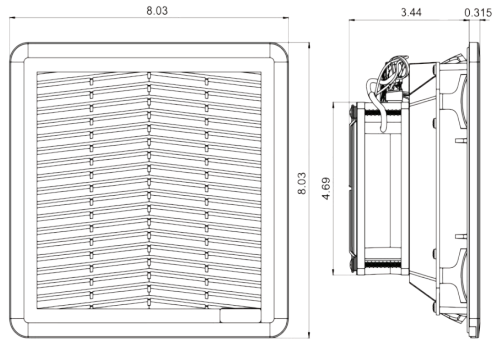

CUTOUT DIMENSIONS (IN)

PFFP250

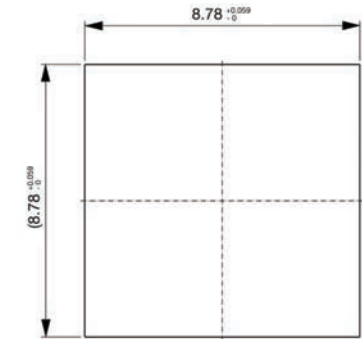
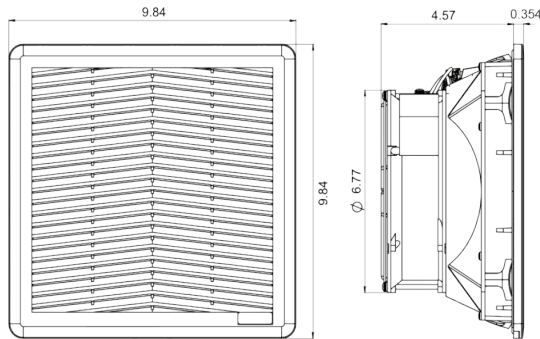

CUTOUT DIMENSIONS (IN)

PFFP450

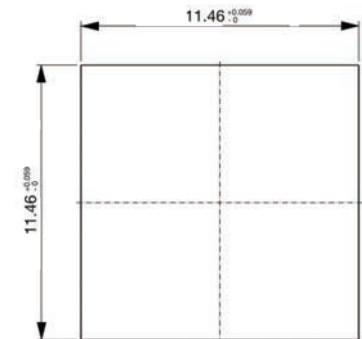
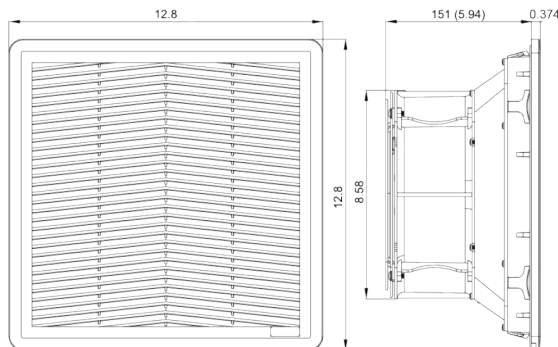

CUTOUT DIMENSIONS (IN)

Accessories:

- Additional filtered exhaust vent
- Replacement filter media
- Plastic adaptor (reduce fan intrusion into electrical enclosure)
- Stainless steel hood (IP56 pressurized wash down protection)
- Thermostats



UL TYPES 12 & 3R

The PFFP Type 12 and Type 3R filtered fan series offers a revolutionary, tool-less, easy-to-mount solution thanks to a system of clips optimized for 18 to 11 gauge thick enclosure panels. The advanced design reduces the risk of water infiltration, increasing operating safety.



RAPID INSTALLATION

The filtered fan and exhaust are installed without screws, by simply pressing into the enclosure cutout.



INNOVATIVE MOUNTING CLIPS

The clips are made of a highly elastic material, for mounting on 11-18 gauge thick plates.



HIDDEN SEAL

A dedicated perimeter seat houses the integrated gasket between the filter unit and the enclosure.



EASY SLIDE OPENING

Cover snaps securely onto the base.



UV PROTECTION

The base and cover are made of UV-resistant PC/ABS plastic.



OPERATIONAL SAFETY

The filter media can be replaced from the outside and without the need for tools.



IMPROVED WATER RESISTANCE

The interface between the base and the cover employs ribbing that facilitates water runoff to the outside.

UL TYPES 12 & 3R | ACCESSORIES



Filter Media

- High performance progressive structure polyolefin fiber with thermal bonding
- High arrestance throughout useful lifetime, providing maximum operational reliability
- Class G3 per EN779
- Can be cleaned, up to 10 times, by careful washing, blowing dry and lightly beating
- 6 filters per package

Part Number	Used On
42246	PFFP085
42247	PFFP150
42248	PFFP250
42249	PFFP450



Stainless Steel Cover

- For high pressure wash down applications
- IP56 protection
- 304 stainless steel
- Easy mounting with stainless steel bayonet bracket and PVC gasket

Part Number	Used On	Width	Height	Depth
40036-4304	PFFP085	7.48"	7.68"	1.63"
40037-4304	PFFP150	9.49"	9.69"	1.63"
40038-4304	PFFP250	11.34"	11.54"	1.63"
40039-4304	PFFP450	14.21"	14.21"	1.63"



Depth Adapter

- For reducing fan intrusion into cabinet by 1 inch
- RAL7035 plastic frame
- Adapter mounts on outside of cabinet

Part Number	Used On	Cutout Dimensions (Width x Height)
40036-4304	PFFP085	4.92" x 4.92"
40037-4304	PFFP150	8.78" x 8.78"
40038-4304	PFFP250	11.46" x 11.46"

INJECTION MOLDED PLASTIC UL TYPE 1

Features:

- Efficient, quiet ball bearing fans
- Nylon or electrostatic polypropylene filter pad
- Snap-on grille for easy filter maintenance
- Angled louvers to resist moisture
- Pressurized operation standard, reverse flow optional
- Operating temperature 14° F to 131° F



Package includes:

- Fan & exhaust vent
- Mounting Hardware
- All kits include integrated gaskets and mounting template

Accessories:

- Thermostats
- Washable replacement filters
- Vent kits



Part Number UL Type 1	CFM Free Flow	CFM With 1 Filter	CFM With 2 Filters	Voltage/Hz.	Rated Amps	RPM
PFFP080-120	75	53	24	115 VAC 50/60	0.11	2900
PFFP080-230	75	53	24	230 VAC 50/60	0.06	2900
PFFP080-D24	89	63	28	24 VDC	0.19	2200
PFFP100-120	131	101	45	115 VAC 50/60	0.17/0.18	3300
PFFP100-230	131	101	45	230 VAC 50/60	0.1/0.11	3300
PFFP100-D24	90	69	31	24 VDC	0.23	3300
PFFP200-120	300	202	91	115 VAC 50/60	0.35/0.40	3300
PFFP200-230	300	202	91	230 VAC 50/60	0.20/0.22	3300
PFFP200-D24	300	202	91	24 VDC	2.1	3900
PFFP390-120	390	280	124	115 VAC 50/60	0.51/0.54	3300
PFFP390-230	390	280	124	230 VAC 50/60	0.30/0.33	3300
PFFP390-D24	270	192	85	24 VDC	0.69	3300
PFFP500-120	850	572	247	115 VAC 50/60	0.50/0.58	2700
PFFP500-230	850	572	247	230 VAC 50/60	0.25/0.30	2700

Model PFFP080

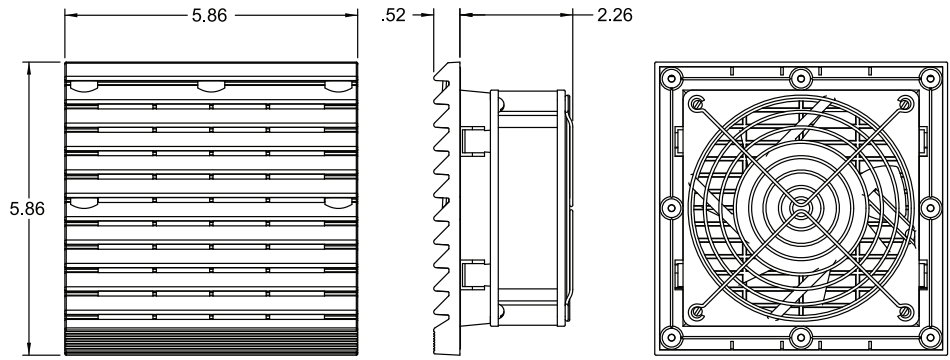

Model PFFP100

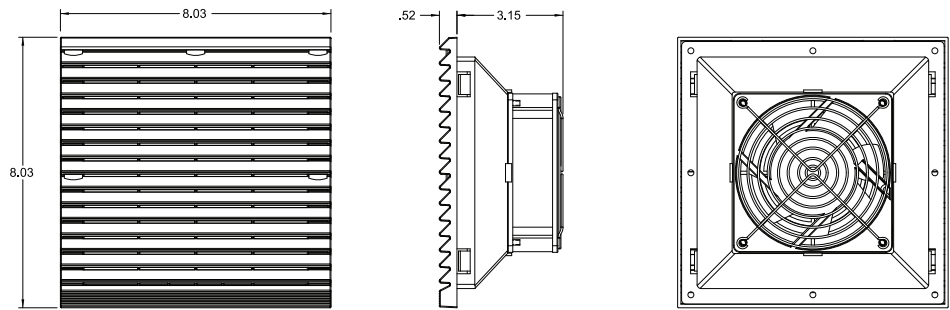

Model PFFP200

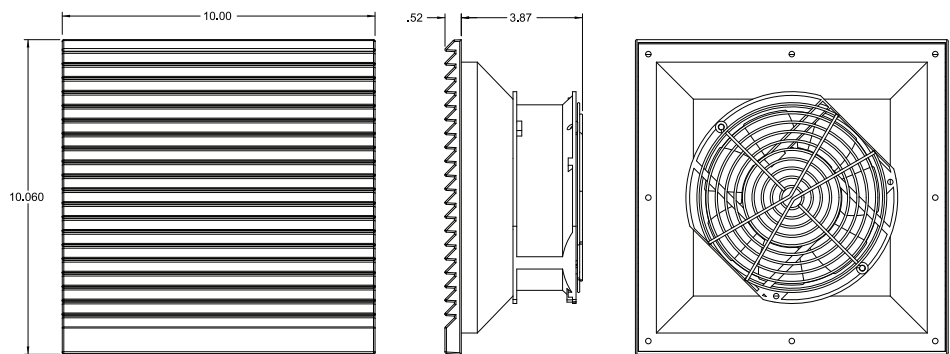

Model PFFP390

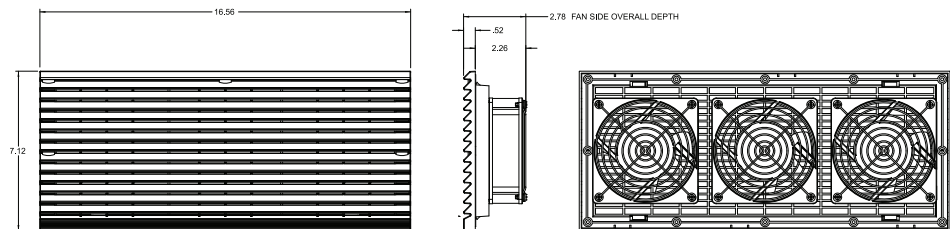

Model PFFP500

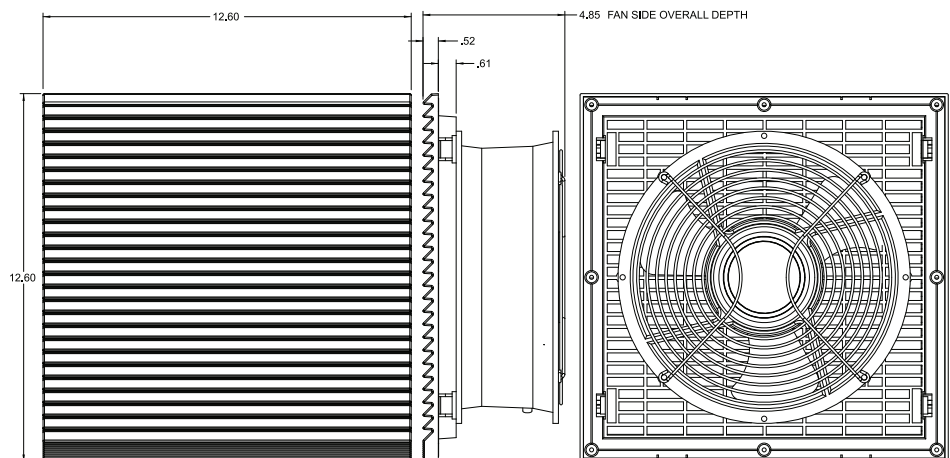

POWDER COATED AND STAINLESS STEEL

Features:

- Efficient, quiet ball bearing fans
- Electrostatic polypropylene filter pad
- Available in 304 Stainless Steel
- Pressurized operation standard, reverse flow optional
- Operating temperature 14° F to 131° F



Package includes:

- Fan & exhaust vent
- Filtered fan, filtered exhaust vent, gaskets, hardware and templates
- Includes 8' cord with plug

(TOP) ANSI 61 Powder Coated Mild Steel
(RIGHT) 304 Stainless Steel (XAX)



Accessories:

- Thermostats
- 3R Shrouds
- Washable replacement filters
- Vent kits

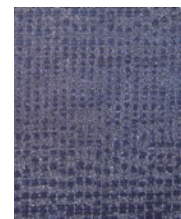

Part Number UL Type 1	Part Number UL Type 3R	CFM Free Flow	CFM With 1 Filter	CFM With 2 Filters	Voltage/Hz.	Rated Amps	RPM
MFFP100-120	MFFP100-120-3R	131	101	45	115 VAC 50/60	0.17/0.18	3300
MFFP100-230	MFFP100-230-3R	131	101	45	230 VAC 50/60	0.1/0.11	3300
MFFP100-D24	MFFP100-D24-3R	90	69	31	24 VDC	0.23	3300
MFFP200-120	MFFP200-120-3R	300	202	91	115 VAC 50/60	0.35/0.40	3300
MFFP200-230	MFFP200-230-3R	300	202	91	230 VAC 50/60	0.20/0.22	3300
MFFP200-D24	MFFP200-D24-3R	300	202	91	24 VDC	2.1	3900
MFFP200-120-01-XAX	MFFP200-120-3R-XAX	300	202	91	115 VAC 50/60	0.35/0.40	3300
MFFP200-230-01-XAX	MFFP200-230-3R-XAX	300	202	91	230 VAC 50/60	0.20/0.22	3300
MFFP200-D24-01-XAX	MFFP200-D24-3R-XAX	300	202	91	24 VDC	2.1	3900
MFFP500-120	MFFP500-120-3R	850	572	247	115 VAC 50/60	0.50/0.58	2700
MFFP500-230	MFFP500-230-3R	850	572	247	230 VAC 50/60	0.25/0.30	2700

Model MFFP 100

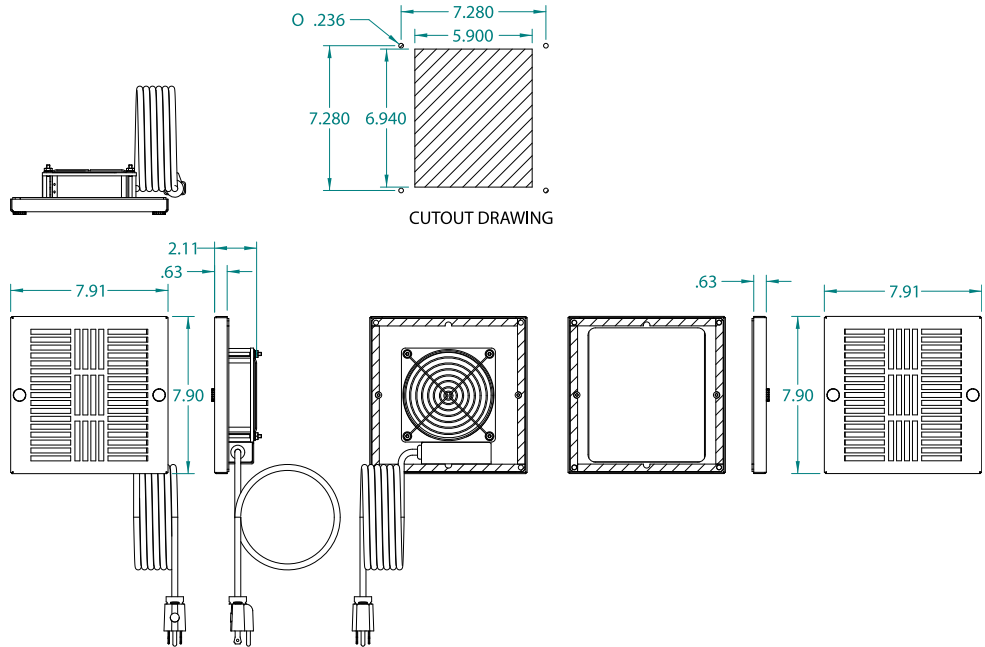

Model MFFP 200

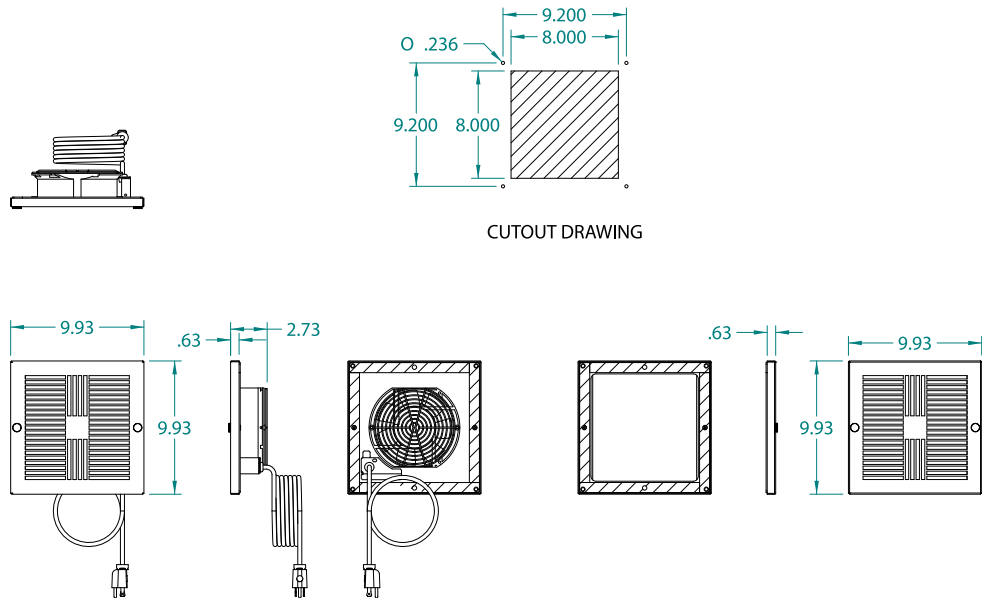

Model MFFP 500

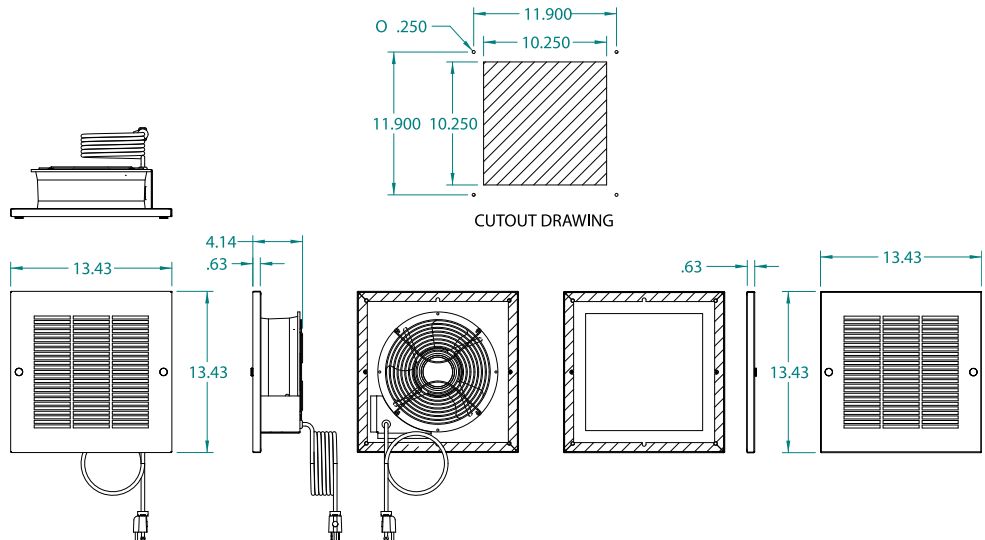

ACCESSORIES | 3R RAIN SHROUDS



APPLICATION*

Our Fan Shroud Kits are designed to keep the elements out of your enclosure while allowing the free air movement from your filtered fan packages.

INSTALLATION

Shrouds come 2 to a kit and are sized to fit neatly over your openings and fans.

SPECIFICS

- 16 Gauge Powder Coated Mild Steel
- Maintains UL Type 3R
- Includes Gaskets On All Three Edges
- Kits Include All Mounting Hardware and Template

THE 3R RAIN SHROUD

is fit over filter fan assembly and fastened from inside.

P/N 100-FFP-3R

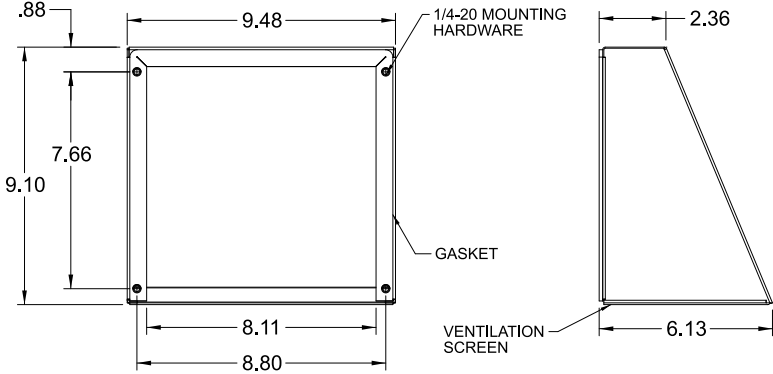

P/N 200-FFP-3R

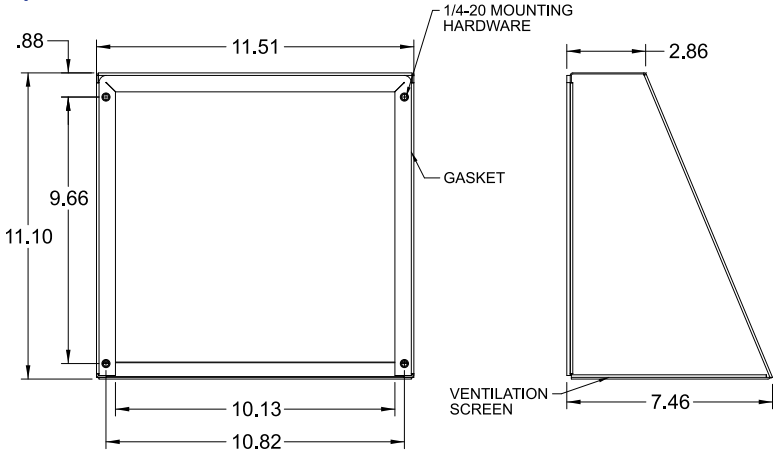

P/N 500-FFP-3R

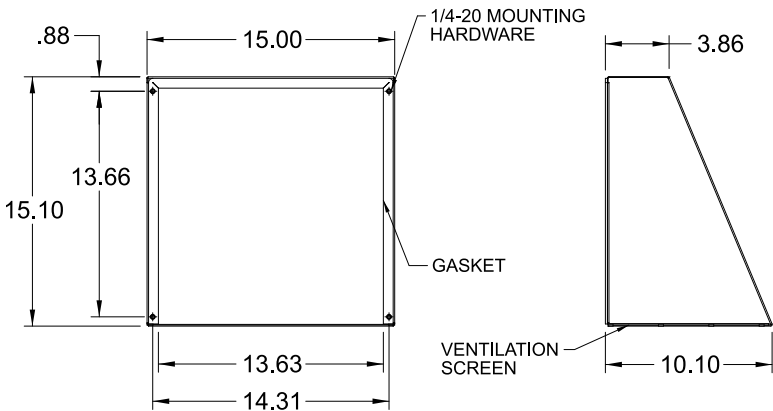

*All information subject to change without notice.

ACCESSORIES | FILTER MEDIA

ELECTROSTATIC POLYPROPYLENE FILTER MEDIA

Our unique 1/4” corrugated polypropylene filtration media features an electrostatic charge that assists in filtering dirt, dust and other irritating pollutants from the air. This industrial filter media is a dense, 3 layer, waffle weave configuration, which enhances the filtration abilities and creates a rigid and durable electrostatic air filter.

Additionally, the Thermal Edge air filtration media can be rinsed or vacuum cleaned, and will not degrade over time as foam does.

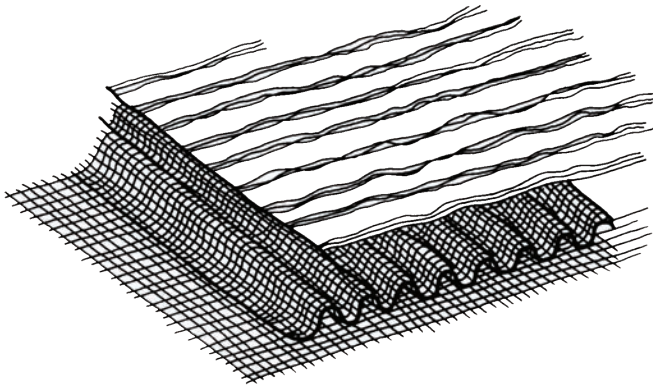

Illustrative View of Multilayered Material



Photo of Actual Material

Media	PermaCool Polypropylene
Weave type	3-D waffle corrugated
U.L. classification	Class 2
Yarn diameter	10 mil
Yarn count (warp/fill)	65/74
Media thickness	.25 inch
Media weight	10.1 oz per square yard
Temperature rating	Operating 180° F, Melting 325°F
Initial resistance	0.04 inches w.g.
Average arrestance efficiency	63%
Dust holding capacity	100 Grams



Thermal Edge Inc.™

ACCESSORIES | THERMOSTATS



THERMOSTAT KTS 111

- Safe wiring with Push-In connection terminal
- Faster and tool-free wiring
- Improved air intakes for ventilation
- Easy adjustability of switch temperature setting
- For use in up to 16,000 ft. altitude

Part #	Contact Type	Scale
11101.0-00	Normally Open*	0 to +60 °C
11101.0-01	Normally Open	-10 to +50 °C
11101.0-02	Normally Open	+20 to +80 °C
11101.9-00	Normally Open	+32 to +140 °F
11101.9-01	Normally Open	+14 to +122 °F



DUAL THERMOSTAT

- ZR 011 Two thermostats in one unit
- One normally open* (blue) & one normally closed (red)
- Or, both normally open
- Each with wide adjustable temperature range
- Available with °F or °C scale
- DIN rail mountable

Part #	NC (red)	NO (blue)
01172.0-01	32 - 140°F	32 - 140°F
01172.0-00	0 - 60°C	0 - 60°C
01176.0-00	0 - 60°C	0 - 60°C
01176.0-01	32 - 140°F	32 - 140°F

*Thermostat normally open: thermostat closes at temperature rise. Comes with a blue temperature dial.

Additional information on these thermostats may be found in the Enclosure Accessories section of this catalog.