

**HIGH CAPACITY HC101/121/151 - 10K, 12K, 15K BTU/H
115V, 230V, AND 480V MODELS**

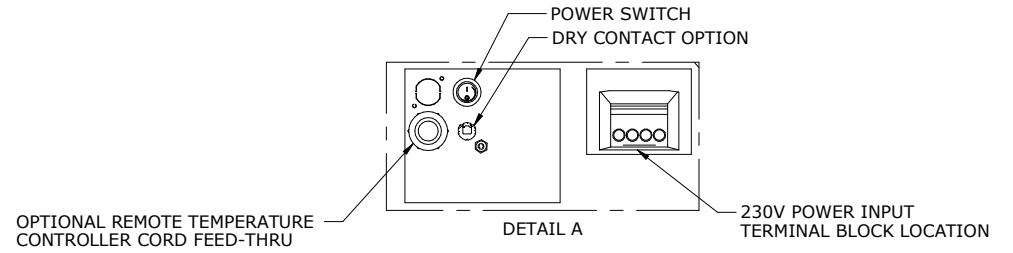

AMBIENT AIR IN.
REUSABLE FILTER:
1) SLIDING 1" FRAME STANDARD
2) 2" FRAME FOR PLEATED FILTER OPTIONAL

DIGITAL
TEMPERATURE
CONTROLLER

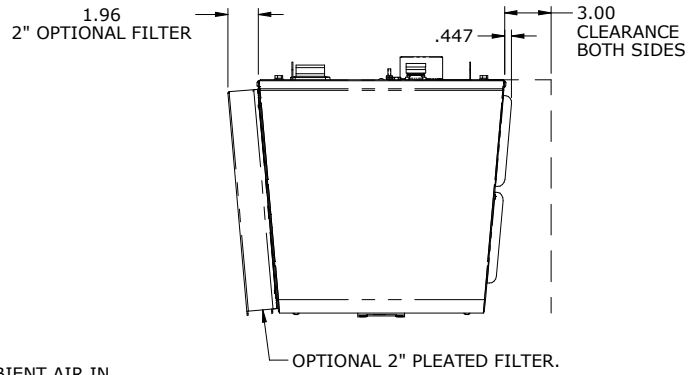
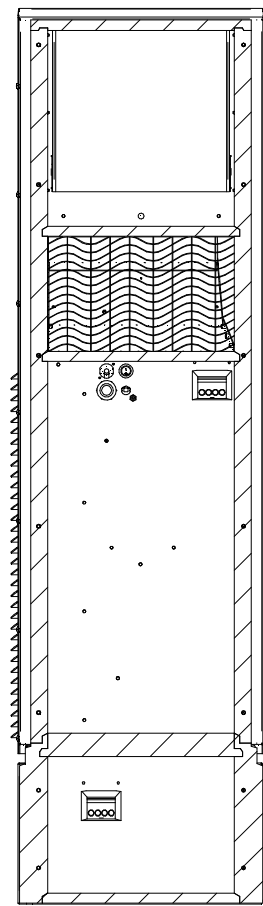
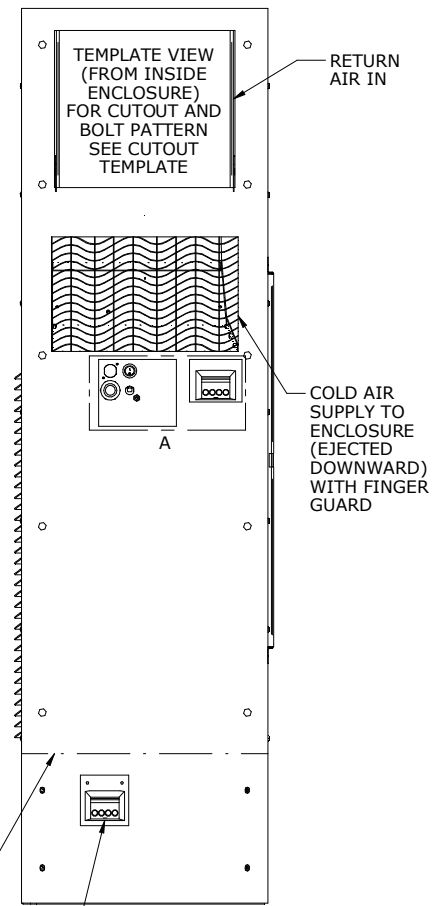
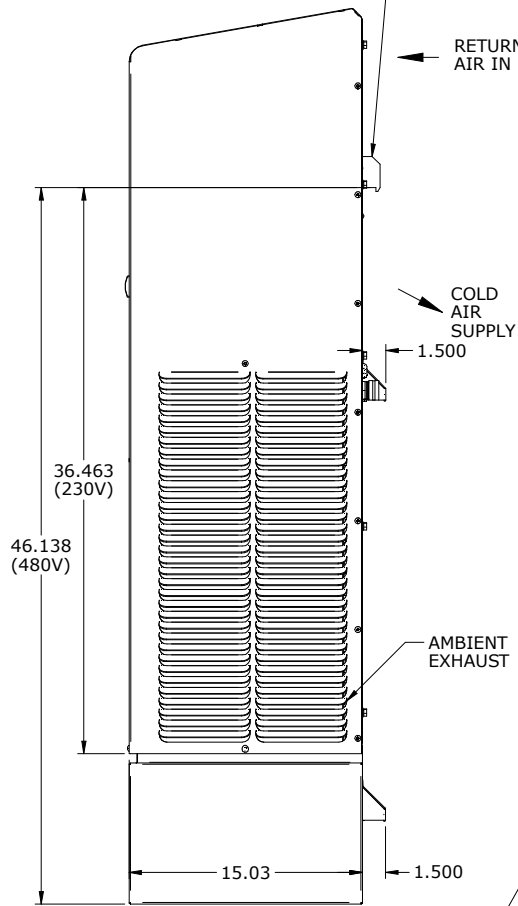
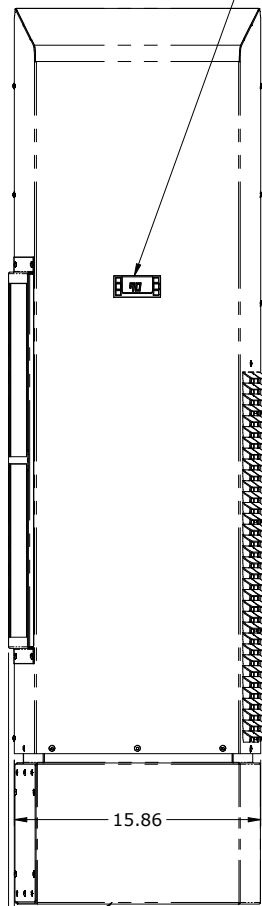
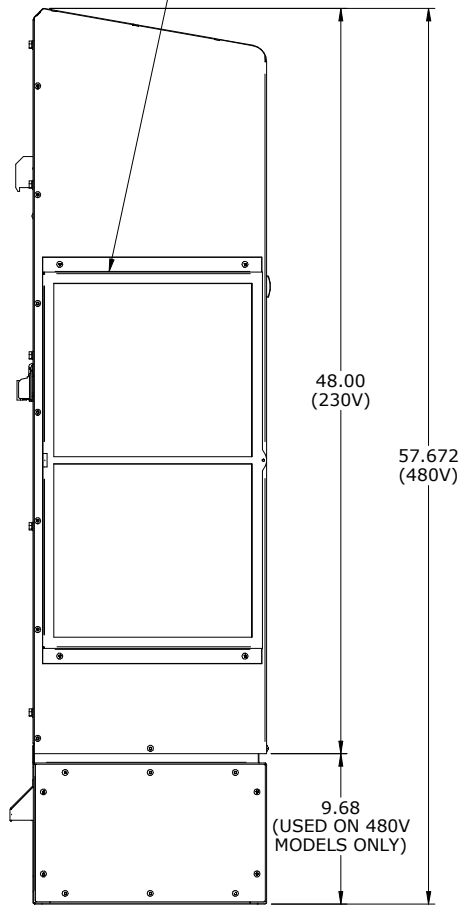

CONDENSATE EMERGENCY OVERFLOW
11/16-16 STRAIGHT THREAD
MAXIMUM THREAD DEPTH .31"

SECTION BELOW LINE
ON 480V MODELS ONLY